

Logic Panel, Graphic Panel

SmartStudio V2.0

PROGRAMMING MANUAL

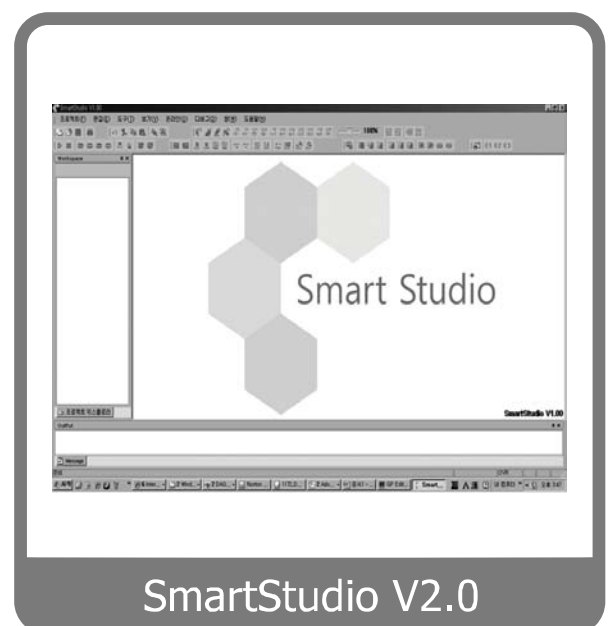

Preface





Thank you very much for selecting Autonics products.

This user manual contains information about the product and its proper use, and should be kept in a place where it will be easy to access.

SmartStudio Programming Manual Guide

- Please familiarize yourself with the information in this manual before using the product.
- This manual provides detailed information on the product's features. It does not offer any guarantee concerning matters beyond the scope of this manual.
- This manual may not be edited or reproduced in either part or whole without permission.
- This programming manual is not provided as part of the product package. Please visit our home-page (www.autonics.com) to download a copy.
- The manual's content may vary depending on changes to the product's software and other unforeseen developments within Autonics, and is subject to change without prior notice. Upgrade notice is provided through our homepage.
- We contrived to describe this manual more easily and correctly. However, if there are any corrections or questions, please notify us these on our homepage.

SmartStudio Programming Manual Symbols

Symbol	Description
 Note	Supplementary information for a particular feature.
 Warning	Failure to follow instructions can result in serious injury or death.
 Caution	Failure to follow instructions can lead to a minor injury or product damage.
 Ex.	An example of the concerned feature's use.
※1	Annotation mark.

※ The specifications and dimensions of this manual are subject to change without any notice.

Table of Contents

	Preface	iii
	SmartStudio Programming Manual Guide	iv
	SmartStudio Programming Manual Symbols	v
	Table of Contents	vi
1	Overview	1
1.1	Feature of SmartStudio	1
1.2	Program Structure and Operation	2
1.2.1	Program Structure	2
1.2.2	Program Operation	2
2	Device	3
2.1	Device list	3
2.2	X device	4
2.3	Y device	4
2.4	M device	4
2.5	S device	5
2.6	D device	5
2.7	T device	6
2.8	C device	7
2.9	Z device	8
2.10	F device	8
2.11	V device	8
2.12	L device	8
2.13	R device	8
3	Create Program	9
3.1	Operation Processing procedures	9
3.1.1	Basic processing procedures	9
3.1.2	Processing procedures when branching	10
3.2	Display the numerical values	12
3.3	Input and output processing	13
3.4	Response delay	14
3.5	Dual coil	14
3.5.1	Definition and diagnosis of dual coil	14
3.6	Pointer use	16
3.7	Operation error	16
3.8	Usages of user defined functions	17
3.9	Notice	20
4	Special device	21
4.1	Special device list	21

4.1.1	Bit special device list	2 1
4.1.2	Word special device list.....	2 4
4.2	Bit special device	2 6
4.2.1	System mode	2 6
4.2.2	System signal.....	2 6
4.2.3	System status.....	2 7
4.2.4	System error.....	2 7
4.2.5	Module status	2 8
4.2.6	System clock	3 0
4.2.7	Operation.....	3 1
4.2.8	System setting.....	3 2
4.2.9	Time setting	3 2
4.2.10	Module setting.....	3 3
4.2.11	Motion control.....	3 4
4.3	Word special device.....	3 6
4.3.1	PLC model.....	3 6
4.3.2	Scan time	3 6
4.3.3	Operation.....	3 6
4.3.4	Step	3 6
4.3.5	Diagnosis.....	3 7
4.3.6	Time.....	3 7
4.3.7	Input filter setting.....	3 8
4.3.8	Time-driven run-time settings.....	3 8
4.3.9	Time-driven interrupt	3 8
4.3.10	Motion control.....	3 9
5	Appendix.....	4 1
5.1	Error code and how to manage it	4 1
5.2	Instruction execution time list	4 3
5.2.1	Basic instruction	4 3
5.2.2	Timer/Counter instruction	4 3
5.2.3	Input comparison instruction	4 4
5.2.4	Comparison instruction	4 5
5.2.5	Transmission instruction.....	4 5
5.2.6	Rotation instruction.....	4 6
5.2.7	Movement instruction	4 6
5.2.8	Arithmetic operation instruction.....	4 7
5.2.9	Exchange instruction.....	4 8
5.2.10	Motion instruction	4 8
5.3	Instruction	4 9
5.3.1	Basic instruction list.....	4 9
5.3.2	Application instruction list.....	5 1
5.3.3	Structures of instruction name.....	6 2

1 Overview

1.1 Feature of SmartStudio

SmartStudio is the exclusive software to write program and debug for LP series. Features and advantages of SmartStudio are as below.

- Supports multi project
You can open up to 5 projects at the same time and write or edit programs.
- Convenient program edit
 - Enables to edit by cell unit
 - Enables to edit with multi window
 - Supports several view functions such as viewing device name, variable name, or device name & comment, etc to edit program easily.
 - You can edit ladder program and mnemonic program at the same time.
- Several monitor function
Supports several monitor function such as monitoring variable, device, system, or time chart, etc.
- Convenient user interface
Easy adaptation for SmartStudio by same basic function of Microsoft window.
- Various message window
Supports various message window for edit or check program easily.
- Real time switching ladder and mnemonic program
Switching ladder or mnemonic program in real time and it is available to write or edit at two editor simultaneously.

1.2 Program Structure and Operation

1.2.1 Program Structure

The program consists of all functions required to execute a specific control, and it is saved embedded RAM of CPU module or flash memory.

These functions are generally classified as below.

Function	Description
Scan Program	Processes a sign repeating regularly in every scan.
Time-driven Interrupt Program	Executes the program according to the set time interval when required to process time conditions as follows. <ul style="list-style-type: none"> When it is required to faster processing than an average process time for a scan When it is required a longer time interval than an average processing time for a scan When it is required to process a program in the designated time interval
Subroutine Program	Executes only when certain condition is fulfilled. (When input condition of CALL instruction is ON)

1.2.2 Program Operation

This program processes the operation according to the following procedures.

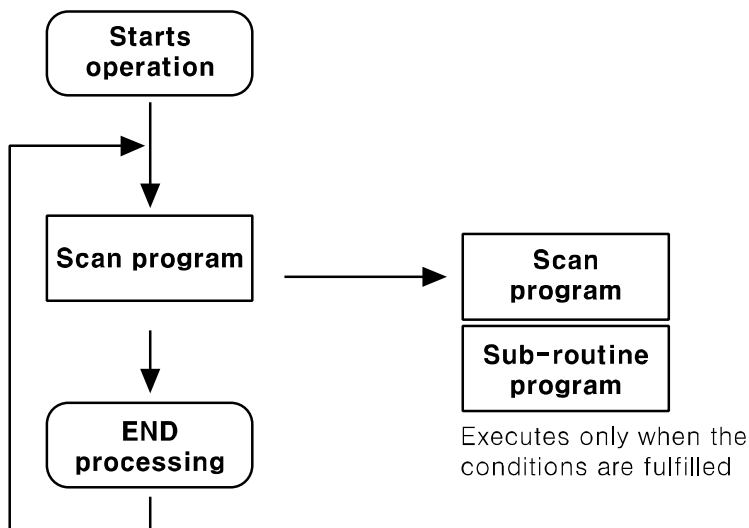

2 Device

2.1 Device list

	Description	Bit range	Word range	GP device(UB)	GP device (UW)
X	Input device	X0 to X255F	X0 to X255	UB70000 to UB7255F	UW7000 to UW7255
Y	Output device	Y0 to Y255F	Y0 to Y255	UB80000 to UB8255F	UW8000 to UW8255
M	Auxiliary device	M0 to M9999F	M0 to M9999	UB200000 to UB29999F	UW20000 to UW29999
S	Step device	S0.0 to S255.99			
D	Data device	D0 to D9999F	D0 to D9999	UB400000 to UB49999F	UW40000 to UW49999
T	Timer contact	T0 to T255		UB100000 to UB10015F	UW10000 to UW10015
T	Timer present value		T0 to T255	UB110000 to UB11255F	UW11000 to UW11255
T	Timer set value		T0 to T255	UB130000 to UB13255F	UW13000 to UW13255
C	Counter contact	C0 to C255		UB150000 to UB15015F	UW15000 to UW15015
C	Counter present value		C0 to C255	UB160000 to UB16255F	UW16000 to UW16255
C	Counter set value		C0 to C255	UB180000 to UB18255F	UW18000 to UW18255
Z	Index device	Z0 to Z255F	Z0 to Z255	UB067000 to UB06955F	UW06700 to UW06955
F	Special device	F0 to F255F	F0 to F255	UB064000 to UB066550F	UW06400 to UW06655
V	Virtual device	V0 to V255F	V0 to V255	UB061000 to UB06355F	UW06100 to UW06355
L	Link device	L0 to L999F	L0 to L999		UW38000 to UW38999
R	File device	R0 to R3999F	R0 to R3999	UB020000 to UB05999F	UW02000 to UW05999
UW /UB	Read area			UB000000 to UB00014F	UW00000 to UW00014
UW /UB	Write area			UB000015 to UB00029F	UW00015 to UW00029
UW /UB	User area			UB000030 to UB01999F	UW00030 to UW01999

2.2 X device

X input device is a device that transfers the signal inputted from an external switch or a button to CPU.

It is able to use A(Normally Open) or B(Normally Closed)Contacts in the program, and also available to with pulse inputs for the contact.

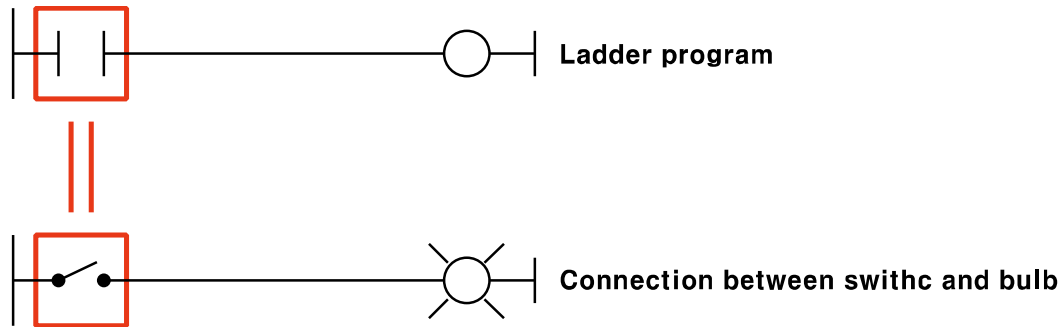

X input device, which is not connected with input terminal, is able to be used as the same function as an inner auxiliary device(M Device).

Because input contact is only retained by external input, be sure that if you want to use it as an external output.

2.3 Y device

Y output device is a device that transfers the inner processing result to externally connected output devices. .

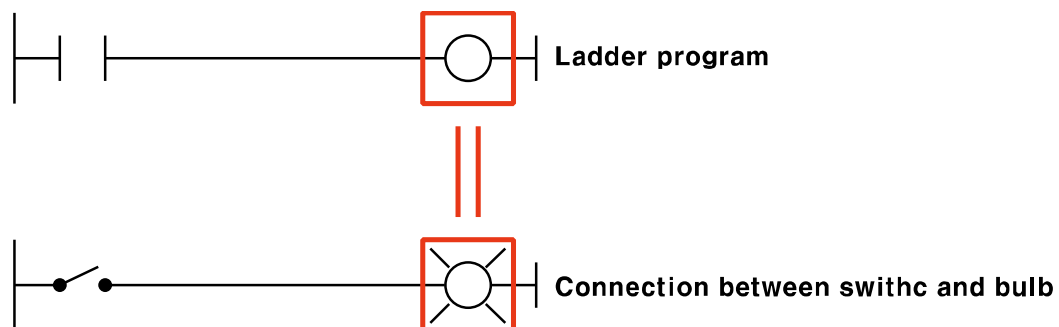

Y device, which is not connected with output terminal, is able to be used as the same function as an inner auxiliary device(M Device).

In case the output device is allocated to an actual external contact and the same output contact is used more than twice to the operand of out instruction in a program, the last used output is output to outside. For further details, refer to '3.5 Dual coil'.

2.4 M device

It is an inner auxiliary device of LP.

It is only able to perform in the program, not able to directly output to outside of LP. It is available to be used as a memory protection device by setting 'Device Latch Range Settings' in [Parameter]-[COMMON].

2.5 S device

It is a step device.

It is a device to control step and used with OUT, SET and RESET instructions. When it is used with SET or RESET instruction, the previous step must be performed first to execute the current step. When it is used with OUT instruction, it executes the last step turned "On" regardless of the order of step.

It is unavailable to be used as a word device, only can be used as a bit device. It is available to be used as a memory protection device by setting 'Device Latch Range Settings' in [Parameter]-[COMMON]. The clear condition, SET XXX.00, is able to execute anytime regardless of the processing steps.

2.6 D device

It is a data device of LP.

It is only able to be used as a word bit, not able to be used as a bit device. When it is used as the 32 bit instruction, D word is operated as lower 16 bit and D+1 word is operated as upper 16 bit as following picture.

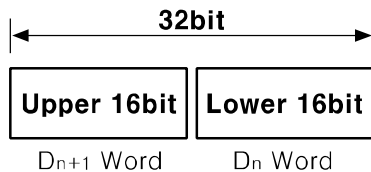

It is available to be used as a memory protection device by setting 'Device Latch Range Settings' in [Parameter]-[COMMON].

2.7 T device

It is a device used with instructions related to Timer.

It consists of three parts; timer contact, timer setting value, timer present value.

Timer contact performs ON/OFF functions according to the result of timer instruction and also available to be used as timer and input instructions.

Timer setting value is a place where a boundary value for the result of timer is saved, and is available to be used with timer and application instructions.

Timer present value is a place where a present value is stored while timer is operating, and user can not set it up directly.

When as following picture, if inputting 100 to "T0" setting value device, "T0" timer contact device turns ON when "T0" present value device becomes 100.

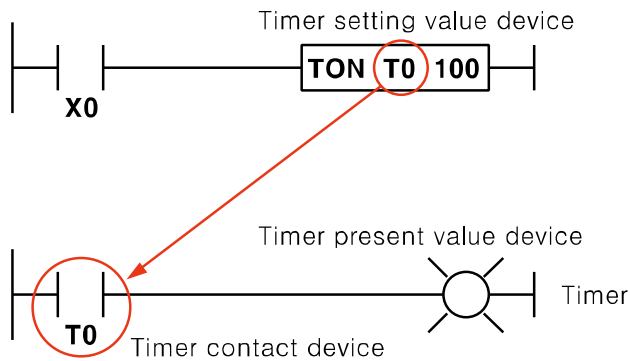

Timer instructions, related to LP Series are TON, TOFF, TMON, TRTG and TMR, and even the same timer device is operated differently depending on each instruction.

The basic cycle of timer device is 10ms, but it is available to be operated in 10ms or 100ms by setting up the device range in parameters.

It is available to be used as a memory protection device by setting 'Device Latch Range Settings' in [Parameter]-[COMMON].

For further details of timer device, refer to '5.3.2.2 Timer instruction'.

2.8 C device

It is a device used with the instructions related to Counter.

It consists of three parts; counter contact, counter setting value, and counter present value.

Counter contact performs ON/OFF functions according to the result of counter instructions, and also available to be used as counter and input instructions.

Counter setting value is a place where a boundary value for the result of count is stored, and is available to be used with counter and application instructions.

Counter present value is a place where a present value is stored while counter is operating, and user can not set it up directly.

When as following picture, if inputting 100 to "C0" setting value device, "C0" contact device turns ON when "C0" present value device becomes 100.

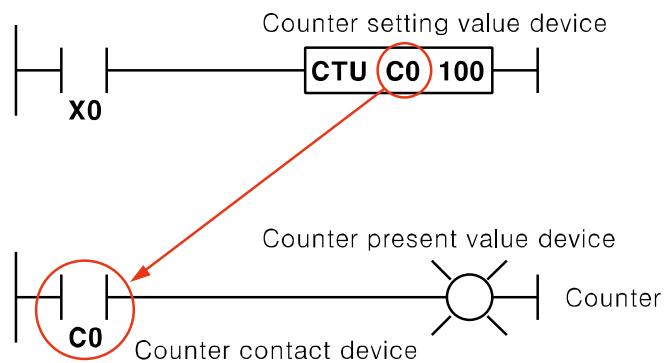

Counter instructions, related to LP Series are CTD, CTU, CTUD and CTR, and even the same counter device is operated differently depending on each instruction.

2.9 Z device

It is a device that is able to designate indirectly a device with using other word device.

When as following picture, if "D0" device value is 10, the value 10 stored in "D0" is transferred to D(0+Z0) device, namely D100 device.

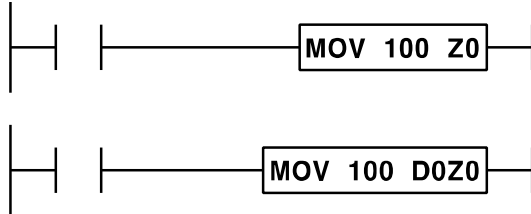

In other words, MOV D0 D0Z0 is interpreted as below.

- MOV D0 D(Value of 0 + Z0)
- MOV D0 D(0+100)
- MOV D0 D100

For another example, if MOV D0 D40Z0 it could be interpreted as below.

- MOV D0 D(Value of 40 + Z0)
- MOV D0 D(40+100)
- MOV D0 D140

It is possible to designate a device address indirectly according to the change of Z device.

2.10 F device

It is a device that sets up the status and operation of LP.

It designates a device that is able to be used separately in input and output instructions, and not able to be used as a memory protection area.

For further details of F device, refer to '4.2 Bit special device' and '4.3 Word special device'.

2.11 V device

It is the used area for matched automatically device area by system when using user defined function. User can not use this device area.

2.12 L device

It is a link device. It is a device sharing link data each other when communicating with other module.

It is available to be used as a memory protection device by setting 'Device Latch Range Settings' in [Parameter]-[COMMON].

2.13 R device

It is a device used when using the recipe function of graphic panel in LP series.

It is available to be used as a memory protection device by setting 'Device Latch Range Settings' in [Parameter]-[COMMON].

3 Create Program

3.1 Operation Processing procedures

3.1.1 Basic processing procedures

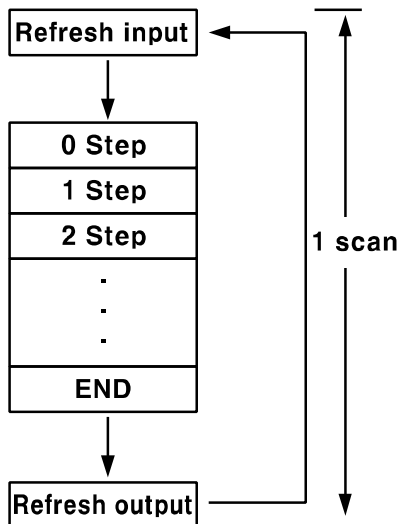

LP program performs input refresh before starting its operation, and begins operation work from the step 0 one by one. Then it executes output refresh after performing the END instruction. Through all these procedures, finally one scan is completed.

- Refresh input: Before executing the program operation, it reads the data from the input contact or module and saves it in designated device area(X Device).
- Refresh output: After completing the program operation, it outputs the data from designated area(Y Device) to the output contact or output module.
- Refresh input and output: Refresh input and output is executed by force at the time to perform the instruction.

3.1.2 Processing procedures when branching

(1) When using JMP to CALL

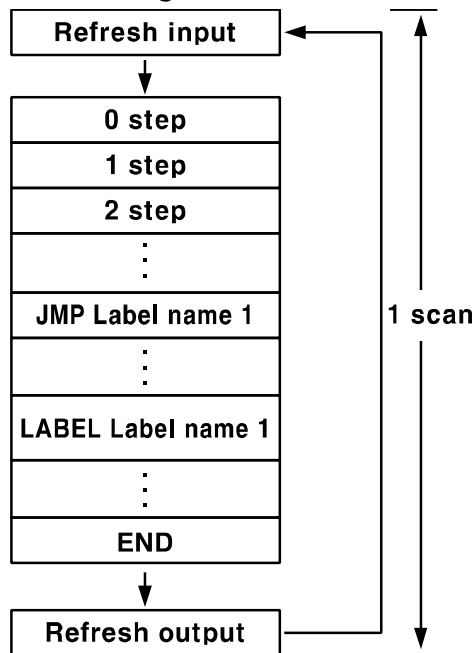

(2) When END instruction is duplicated

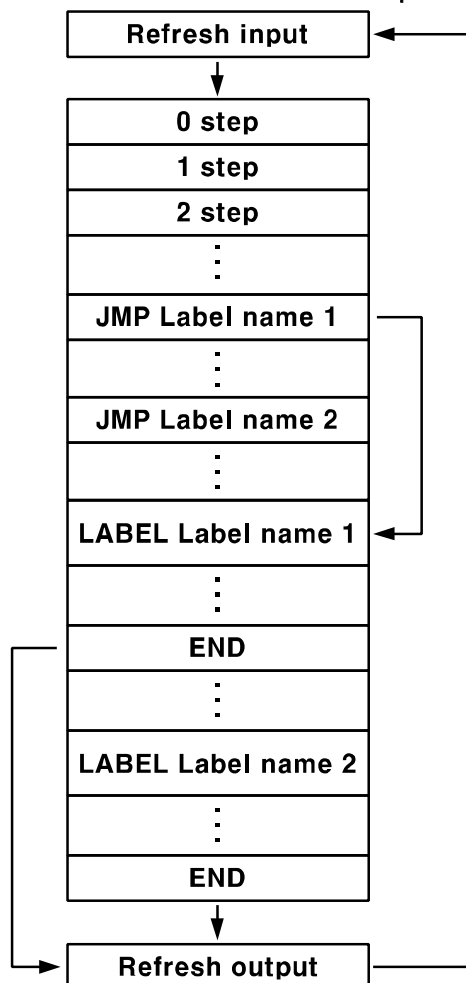

If the END instruction executes while the program is being processed, it exits the operation without performing the below program.

(3) Interrupt, Subroutine, User defined functions

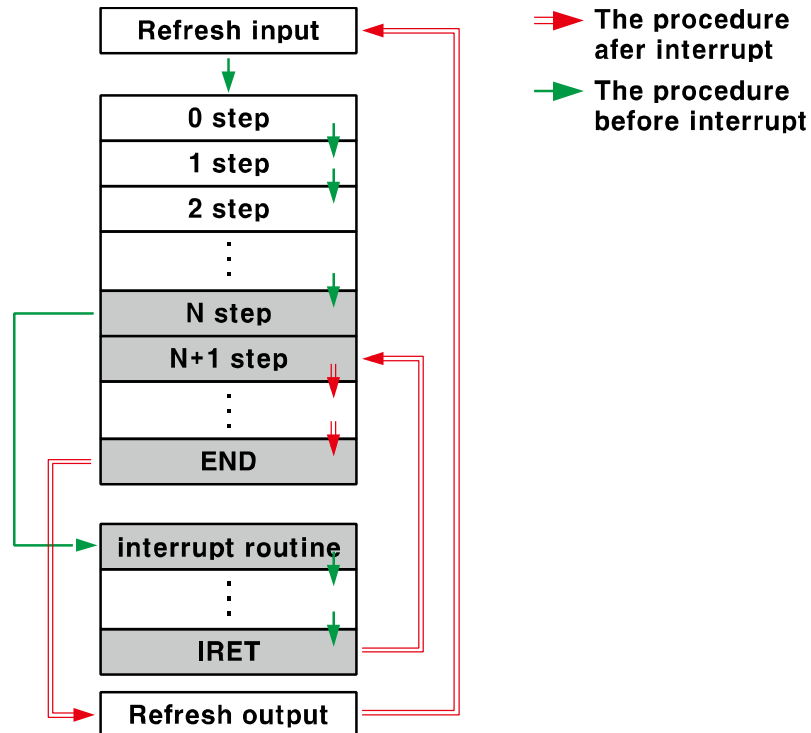

As above example for interrupt program, programs containing interrupt, subroutine and user defined functions, firstly jump to the subroutine and perform it completely, and then go to the main program again, finally keep continuing to execute the program from the next step of the stopped step.

3.2 Display the numerical values

(1) Decimal number

Setting values of timer and counter, addresses of word device and S device, for designate the numeral values in instruction operands, for designate the number of operation times in instruction operands

Ex) 1, 3, 10, 19...

(2) Hexadecimal number

Setting values of timer and counter, addresses of bit devices such as X, Y and M, for designate the numeral values in instruction operands, for designate the number of operation times in instruction operands

Ex) h0001, h0003, h000a, h0013...

(3) Binary number

Setting values of timer and counter, for designate the numeral values and the number of operation times is displayed with decimal or hexadecimal number, these kinds of numeric values are usually converted into binary numbers in LP.

Ex) 0001, 0011, 1010, 00010011 ...

(4) BCD

BCD is a numeric system that represents the decimal digits consisted of 0 to 9 as the binary numeric system of 4 bits.

Ex) 0001, 0011, 0001 0000, 0001 1001 ...

3.3 Input and output processing

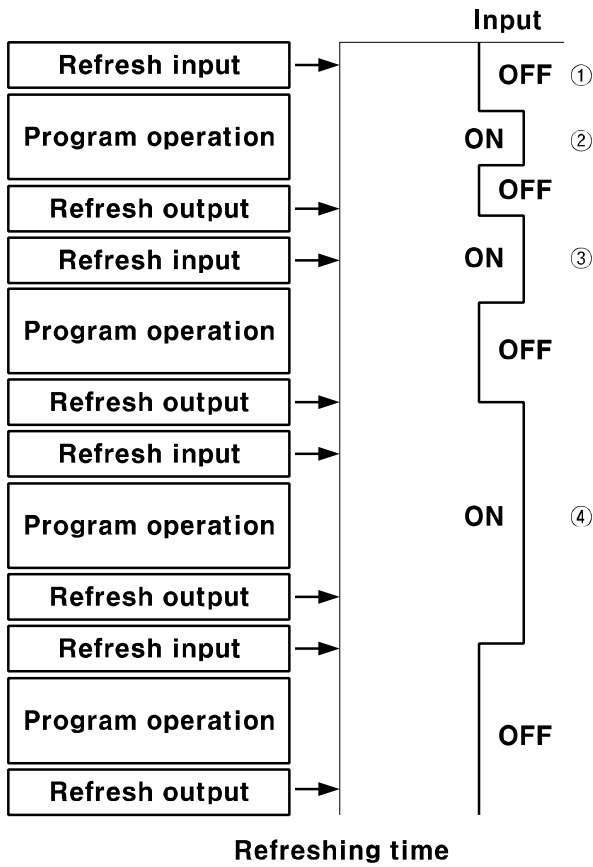

No.	Description
①	Input is OFF.
②	It is not time to refresh input, input is OFF.
③	It is ON at the time to refresh input, input is ON. But the length of input signal is shorter than scan cycle, it may not recognize as ON depending on the time to refresh input.
④	Because the input retains ON during a cycle of scan, it turns ON regardless of refreshing input time. ※The minimum input retaining time of LP series is 1ms. Even though the input is entered at the time of refreshing input, the input is invalid if it is not able to maintain for 1ms.

3.4 Response delay

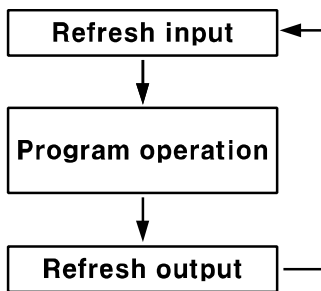

The program is processed as above, therefore in case of input/output the response delay may be occurred due to operation time. If you need to perform input/output processing while program is being operated, it is available with using REF instructions(Refresh input/output).

3.5 Dual coil

3.5.1 Definition and diagnosis of dual coil

(1) Definition of dual coil

Dual coil indicates that the same output coil is used in duplicate in a program.

(2) Diagnosis of dual coil

- 1) When the same device is used as operand of OUT instruction more than twice in a program.

- Not dual coil

Step	Instruction	OP1	OP2
0	LOAD	M00000	
1	OUT	M00001	
2	LOAD	M00002	
3	RST	M00001	
4	END		

- Dual coil

Step	Instruction	OP1	OP2
0	LOAD	M00000	
1	OUT	M00001	
2	LOAD	M00002	
3	OUT	M00001	
4	END		

- 2) When the same device of counter or timer is used as timer/counter instruction more than twice in a program.
- Not dual coil

Step	Instruction	OP1	OP2
0	LOAD	M00000	
1	LOAD	M00001	
2	CTU	C000	100
7	LOAD	M00002	
8	MOV	100	C000
13	END		

- Dual coil

Step	Instruction	OP1	OP2
0	LOAD	M00000	
1	LOAD	M00001	
2	CTU	C000	100
7	LOAD	M00002	
8	LOAD	M00003	
9	CTU	C000	10
14	END		

It is not regard as dual coil when the same device is used in other instructions.

(3) Process dual coil as error

Select [Tool]-[Program Checking]-[Program Checking Options] of SmartStudio menu, 'Checking Program Options' dialog box appears. Check 'Process dual coil as error' and it processes dual coil as an error and you cannot download the program. If not checking 'Process dual coil as error' you can download the program.

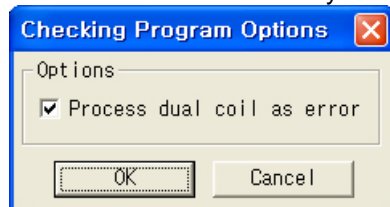

3.6 Pointer use

Pointer usually refers to the same kind of device having a corresponding device value as an address. Using a pointer indicates that the asterisk mark(“*”) attaches in front of device in order to use it as a pointer. (ex : *M1000)

0	F00010				H0064
		MOV	H0064	M0010	
6	F00010				H000A
		MOV	H000A	*M0010	
12	F00010				H000A
		MOV	*M0010	M0100	
18	M00001				Y00000
20					END



Ex.

When as following mnemonic codes exist,

MOV *M0010 D0050

If the value 100 is stored in M0010, the above mnemonic code can be interpreted as follows.

MOV M0100 D0050

If the value 30 is stored in D0050, the above mnemonic code can be interpreted as follows.

MOV 30 D0050

3.7 Operation error

If it is a numerical operation error caused by the problems, which are occurred during performing the user program, it is displayed in error flag and the system continues to operate. When the operation time is longer than the setting time for scan delay monitoring during performing the operation, the system is not operated any more.

- Time-driven operation error (F35 bit)

When the scan time is longer than the time-driven setting time, it is SET. When the scan time is shorter than the time-driven setting time, its corresponding bit turns OFF from ON.

- Operation error flag (At present) (F68 bit)

When an error occurs in numerical operation during performing the user program, its corresponding bit is SET. When changing to all modes excluded STOP mode and no operation error after a scan and program download and power reset, its corresponding bit turns OFF from ON.

- Operation error flag (Retaining) (F69 bit)

It is used to figure out the history of operation error occurrences. If the first operation error occurs while scanning, the corresponding bit is SET and turns OFF when the power is reset.

3.8 Usages of user defined functions

This function is to reuse a block, possibly to be used in other project, by making it library while you are creating a program. The program made in library is saved as a file so that it is available to use in other projects or PC again.

User calls “user defined functions” as forms of FCALL cmd op1 op2... and uses it as forms of FUNC cmd.

(1) How to register user defined functions

1st Select the block you want to register as below.

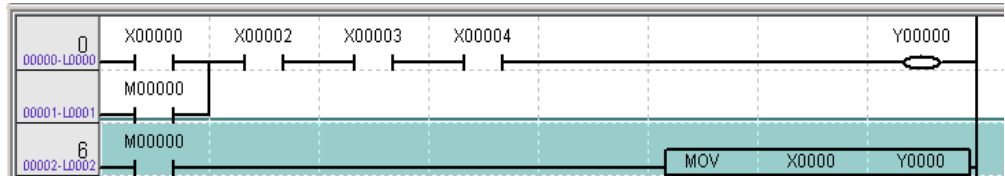

2nd Select [Tool]-[Register User Defined Function] of menu, press Shift + F10, or click

 of ladder tool bar. ‘Register User Defined Function’ dialog box appears.

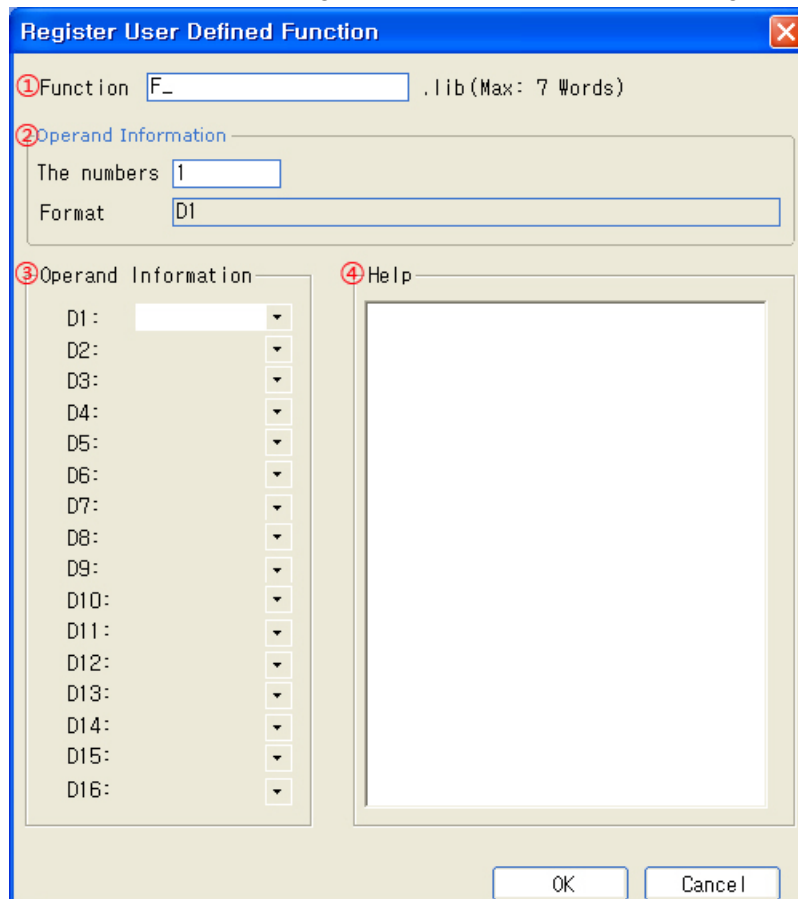

No.	Description
①	Input a user defined function name.
②	Set the number of operands to use.
③	Set the number of each operand's device as much as the designated number of operands.
④	Describe for the user defined functions you want to register.

3rd If click "OK" button after completing above process, the user defined function is registered. The registered user defined function is stored with the function name.lib file in \WLIB folder.

(2) How to use user defined functions

1st Select [Tool]-[User Defined Function], press Ctrl + F11, or click  of ladder tool bar. 'Function List' dialog box appears.

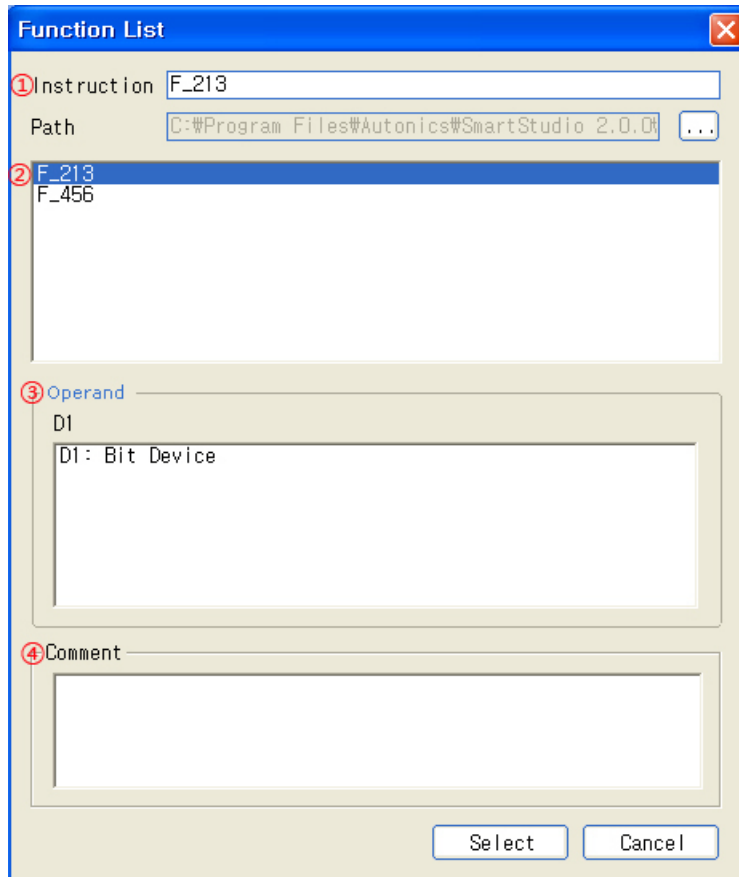

No.	Description
①	Displays the selected user defined function name.
②	Displays user defined functions stored in the designated folders.
③	Displays used device in the selected user defined function.
④	Displays registered description for the selected user defined function.

2nd User defined functions are applied when click 'Select'. If user defined function or operand is not entered correctly, and when you click 'Select', 'Function List' dialog box is not closed and user defined function is not applied to ladder program. Click 'Cancel' and the user defined functions list is closed automatically regardless of whatever you input.

3rd In the place where call the function, call with FCALL instruction, and in the place where the function is called, is called with FUNC instruction.

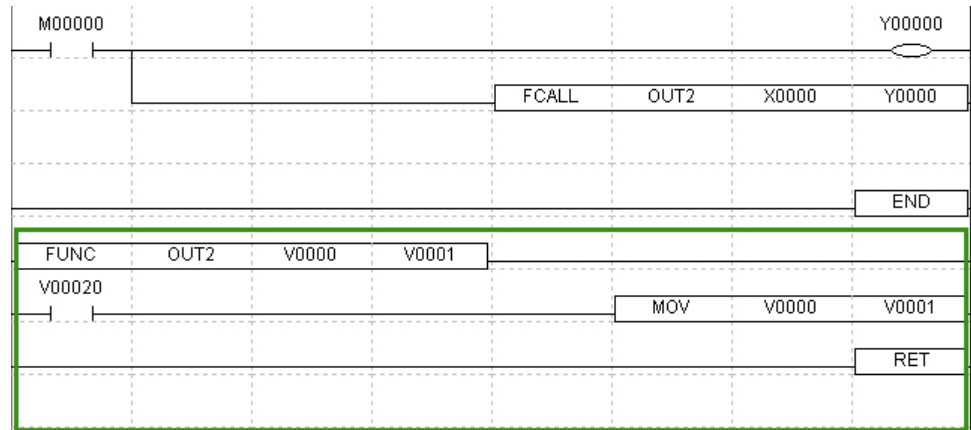

3.9 Notice

(1) Input/output processing and response delay

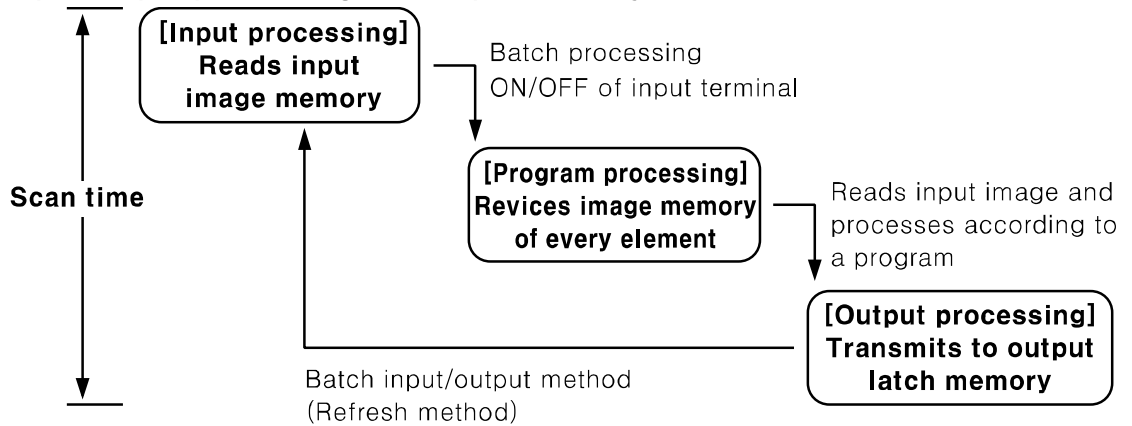

It is processing input/output through executing the above processing repeatedly. Therefore, please be aware that there is a response delay by operation cycle except by the operation time of input filter or output elements in sequence control.

(2) Dual coil

When the output coil is used in multi places, usually the last programmed coil is activated first.

For example,

```

LOAD X0
OUT Y0 (First Y0)
LOAD Y0
OUT Y1
LOAD X1

```

```

OUT Y0 (Second Y0)

```

In above, X0 = ON, X1 = OFF.

For first Y0 is X0 = ON, virtual memory is ON and output Y1 is ON. However, second Y0 is X1 = OFF, virtual memory turns OFF.

Therefore, actual external output is Y0 = ON, Y1 = ON. If using dual output as explained above, the latter one is activated first. Therefore, pay attention when using dual coil. For whether to using dual coil or not, refer to '3.5 Dual coil'.

4 Special device

4.1 Special device list

4.1.1 Bit special device list

Name	GP device	LP device	Applied model
Run mode	UB64000	F00000	LP-S044; LP-S070
Stop mode	UB64001	F00001	LP-S044; LP-S070
Pause mode	UB64002	F00002	LP-S044; LP-S070
Debug mode	UB64003	F00003	LP-S044; LP-S070
Normally ON	UB64010	F00010	LP-S044; LP-S070
Normally OFF	UB64011	F00011	LP-S044; LP-S070
1 scan ON	UB64012	F00012	LP-S044; LP-S070
1 scan OFF	UB64013	F00013	LP-S044; LP-S070
Scan pulse	UB64014	F00014	LP-S044; LP-S070
Time synchronous pulse	UB64015	F00015	LP-S044; LP-S070
While operating forced input	UB64020	F00020	LP-S044; LP-S070
While operating forced output	UB64021	F00021	LP-S044; LP-S070
While running time-driven	UB64024	F00024	LP-S044; LP-S070
Output allowance while debugging	UB64025	F00025	LP-S044; LP-S070
Back-up battery errors(At present)	UB6402C	F0002C	LP-S044; LP-S070
Back-up battery errors (Retaining)	UB6402D	F0002D	LP-S044; LP-S070
Error occurrence	UB64030	F00030	LP-S044; LP-S070
Errors related to PLC program	UB64034	F00034	LP-S044; LP-S070
Time-driven operation error	UB64035	F00035	LP-S044; LP-S070
Time setting error flag	UB64036	F00036	LP-S044; LP-S070
Communication errors	UB64038	F00038	LP-S044; LP-S070
I/O setting value errors	UB64039	F00039	LP-S044; LP-S070
Watchdog timer error flag	UB6403A	F0003A	LP-S044; LP-S070
Using inner device of SLOT 0	UB64040	F00040	LP-S044; LP-S070
Using inner device of SLOT 1	UB64041	F00041	LP-S044; LP-S070
Using inner device of SLOT 2	UB64042	F00042	LP-S044; LP-S070
Using inner device of SLOT 3	UB64043	F00043	LP-S044; LP-S070
Using inner device of SLOT 4	UB64044	F00044	LP-S044; LP-S070
Using inner device of SLOT 5	UB64045	F00045	LP-S044; LP-S070
Using inner device of SLOT 6	UB64046	F00046	LP-S044; LP-S070
Using inner device of SLOT 7	UB64047	F00047	LP-S044; LP-S070
Using inner device of SLOT 8	UB64048	F00048	LP-S044; LP-S070
Using inner device of SLOT 9	UB64049	F00049	LP-S044; LP-S070
Using inner device of SLOT 10	UB6404A	F0004A	LP-S044; LP-S070
Using inner device of SLOT 11	UB6404B	F0004B	LP-S044; LP-S070
Using inner device of SLOT 12	UB6404C	F0004C	LP-S044; LP-S070

Name	GP device	LP device	Applied model
Using inner device of SLOT 13	UB6404D	F0004D	LP-S044; LP-S070
Using inner device of SLOT 14	UB6404E	F0004E	LP-S044; LP-S070
Using inner device of SLOT 15	UB6404F	F0004F	LP-S044; LP-S070
0.5ms clock(in reserve)	UB64050	F00050	LP-S044; LP-S070
1ms clock(in reserve)	UB64051	F00051	LP-S044; LP-S070
2ms clock(in reserve)	UB64052	F00052	LP-S044; LP-S070
5ms clock(in reserve)	UB64053	F00053	LP-S044; LP-S070
10ms clock	UB64054	F00054	LP-S044; LP-S070
20ms clock	UB64055	F00055	LP-S044; LP-S070
50ms clock	UB64056	F00056	LP-S044; LP-S070
100ms clock	UB64057	F00057	LP-S044; LP-S070
200ms clock	UB64058	F00058	LP-S044; LP-S070
500ms clock	UB64059	F00059	LP-S044; LP-S070
1s clock	UB6405A	F0005A	LP-S044; LP-S070
2s clock	UB6405B	F0005B	LP-S044; LP-S070
5s clock	UB6405C	F0005C	LP-S044; LP-S070
10s clock	UB6405D	F0005D	LP-S044; LP-S070
60s clock	UB6405E	F0005E	LP-S044; LP-S070
Zero flag	UB64060	F00060	LP-S044; LP-S070
Carry flag	UB64061	F00061	LP-S044; LP-S070
Borrow flag	UB64062	F00062	LP-S044; LP-S070
Operation error flag(At present)	UB64068	F00068	LP-S044; LP-S070
Operation error flag(Retaining)	UB64069	F00069	LP-S044; LP-S070
Settings for full output restriction	UB64070	F00070	LP-S044; LP-S070
Output reset restriction	UB64071	F00071	LP-S044; LP-S070
Start-up time-driven activity	UB64074	F00074	LP-S044; LP-S070
Change the time-driven run-time	UB64075	F00075	LP-S044; LP-S070
Change the time-driven interrupt time	UB64076	F00076	LP-S044; LP-S070
Retaining output status while stop	UB64077	F00077	LP-S044; LP-S070
Operating conditions for extended module function	UB64078	F00078	LP-S044; LP-S070
Default filter setting flag	UB64079	F00079	LP-S044; LP-S070
Filter setting change flag	UB6407A	F0007A	LP-S044; LP-S070
Time setting	UB64080	F00080	LP-S044; LP-S070
+/- 30 sec correction of time setting	UB64081	F00081	LP-S044; LP-S070
Settings for using inner device of SLOT0 module function	UB64090	F00090	LP-S044; LP-S070
Settings for using inner device of SLOT1 module function	UB64091	F00091	LP-S044; LP-S070
Settings for using inner device of SLOT2 module function	UB64092	F00092	LP-S044; LP-S070
Settings for using inner device of SLOT3 module function	UB64093	F00093	LP-S044; LP-S070

Name	GP device	LP device	Applied model
Settings for using inner device of SLOT4 module function	UB64094	F00094	LP-S044; LP-S070
Settings for using inner device of SLOT5 module function	UB64095	F00095	LP-S044; LP-S070
Settings for using inner device of SLOT6 module function	UB64096	F00096	LP-S044; LP-S070
Settings for using inner device of SLOT7 module function	UB64097	F00097	LP-S044; LP-S070
Settings for using inner device of SLOT8 module function	UB64098	F00098	LP-S044; LP-S070
Settings for using inner device of SLOT9 module function	UB64099	F00099	LP-S044; LP-S070
Settings for using inner device of SLOT10 module function	UB6409A	F0009A	LP-S044; LP-S070
Settings for using inner device of SLOT11 module function	UB6409B	F0009B	LP-S044; LP-S070
Settings for using inner device of SLOT12 module function	UB6409C	F0009C	LP-S044; LP-S070
Settings for using inner device of SLOT13 module function	UB6409D	F0009D	LP-S044; LP-S070
Settings for using inner device of SLOT14 module function	UB6409E	F0009E	LP-S044; LP-S070
Settings for using inner device of SLOT15 module function	UB6409F	F0009F	LP-S044; LP-S070
Using Motion CH1	UB64100	F00100	LP-S070
Moving of Motion CH1	UB64101	F00101	LP-S070
Using acceleration of Motion CH1	UB64102	F00102	LP-S070
Driving with set speed of Motion CH1	UB64103	F00103	LP-S070
Decelerating of Motion CH1	UB64104	F00104	LP-S070
Dwelling of Motion CH1	UB64105	F00105	LP-S070
Finish driving of CH1	UB64106	F00106	LP-S070
Detecting S/W lower limit of Motion CH1	UB64107	F00107	LP-S070
Detecting S/W upper limit of Motion CH1	UB64108	F00108	LP-S070
Detecting H/W lower limit of Motion CH1	UB64109	F00109	LP-S070
Detecting H/W upper limit of Motion CH1	UB6410A	F0010A	LP-S070
Using Motion CH2	UB64120	F00120	LP-S070
Moving of Motion CH2	UB64121	F00121	LP-S070
Using acceleration of Motion CH2	UB64122	F00122	LP-S070
Driving with set speed of Motion CH2	UB64123	F00123	LP-S070
Decelerating of Motion CH2	UB64124	F00124	LP-S070
Dwelling of Motion CH2	UB64125	F00125	LP-S070

Name	GP device	LP device	Applied model
Finish driving of CH2	UB64126	F00126	LP-S070
Detecting S/W lower limit of Motion CH2	UB64127	F00127	LP-S070
Detecting S/W upper limit of Motion CH2	UB64128	F00128	LP-S070
Detecting H/W lower limit of Motion CH2	UB64129	F00129	LP-S070
Detecting H/W upper limit of Motion CH2	UB6412A	F0012A	LP-S070
Jog starting forward of Motion CH1	UB64501	F00501	LP-S070
Jog starting backward of Motion CH1	UB64502	F00502	LP-S070
Jog starting forward of Motion CH2	UB64503	F00503	LP-S070
Jog starting backward of Motion CH2	UB64504	F00504	LP-S070
Channel error of Motion CH1	UB64110	F00110	LP-S070
Emergency stop error of Motion CH1	UB6411F	F0011F	LP-S070
Channel error of Motion CH2	UB64130	F00130	LP-S070
Emergency stop error of Motion CH2	UB6413F	F0013F	LP-S070

4.1.2 Word special device list

Name	GP device	LP device	Applied model
Error code check of Motion CH1	UW6420	F20	LP-S070
Error code check of Motion CH2	UW6421	F21	LP-S070
Current position of Motion CH1	UW6460	F60	LP-S070
Current speed of Motion CH1	UW6462	F62	LP-S070
Current action No. of Motion CH1	UW6464	F64	LP-S070
Current pattern No. of Motion CH1	UW6465	F65	LP-S070
Current home position of Motion CH1	UW6466	F66	LP-S070
Setting speed of Motion CH1	UW6468	F68	LP-S070
Current position of Motion CH2	UW6470	F70	LP-S070
Current speed of Motion CH2	UW6472	F72	LP-S070
Current action No. of Motion CH2	UW6474	F74	LP-S070
Current pattern No. of Motion CH2	UW6475	F75	LP-S070
Current home position of Motion CH2	UW6476	F76	LP-S070
Setting speed of Motion CH2	UW6478	F78	LP-S070
PLC series and model code	UW6500	F100	LP-S044; LP-S070
System version	UW6501	F101	LP-S044; LP-S070
Released date of the version(Year)	UW6506	F106	LP-S044; LP-S070
Released date of the version(Date)	UW6507	F107	LP-S044; LP-S070
Present scan time	UW6510	F110	LP-S044; LP-S070

Name	GP device	LP device	Applied model
Min. scan time	UW6511	F111	LP-S044; LP-S070
Max. scan time	UW6512	F112	LP-S044; LP-S070
Average scan time	UW6513	F113	LP-S044; LP-S070
Scan time count	UW6514	F114	LP-S044; LP-S070
Step operation generated error (At present)	UW6520	F120	LP-S044; LP-S070
Step operation generated error (Retaining)	UW6521	F121	LP-S044; LP-S070
Error step	UW6530	F130	LP-S044; LP-S070
Break step	UW6531	F131	LP-S044; LP-S070
Self-diagnosis error code	UW6540	F140	LP-S044; LP-S070
Time setting (Year)	UW6550	F150	LP-S044; LP-S070
Time setting (Month)	UW6551	F151	LP-S044; LP-S070
Time setting (Date)	UW6552	F152	LP-S044; LP-S070
Time setting (Hour)	UW6553	F153	LP-S044; LP-S070
Time setting (Min)	UW6554	F154	LP-S044; LP-S070
Time setting (Sec)	UW6555	F155	LP-S044; LP-S070
Time setting (Day)	UW6556	F156	LP-S044; LP-S070
Input filter settings	UW6560	F160	LP-S044; LP-S070
Time-driven run-time settings	UW6561	F161	LP-S044; LP-S070
Watchdog timer settings	UW6562	F162	LP-S044; LP-S070
Time-driven interrupt cycle settings 1	UW6570	F170	LP-S044; LP-S070
Time-driven interrupt cycle settings 2	UW6571	F171	LP-S044; LP-S070
Time-driven interrupt cycle settings 3	UW6572	F172	LP-S044; LP-S070
Time-driven interrupt cycle settings 4	UW6574	F174	LP-S044; LP-S070
Time-driven interrupt cycle settings 5	UW6575	F175	LP-S044; LP-S070
Time-driven interrupt cycle settings 6	UW6576	F176	LP-S044; LP-S070
Time-driven interrupt cycle settings 7	UW6577	F177	LP-S044; LP-S070
Time-driven interrupt cycle settings 8	UW6578	F178	LP-S044; LP-S070

4.2 Bit special device

4.2.1 System mode

Name	Function	Initial value	R/W	GP device	LP device
Run mode	<ul style="list-style-type: none"> When system mode is run, it turns ON When system mode changes from run to other mode, it turns OFF 	OFF	R	UB64000	F00000
Stop mode	<ul style="list-style-type: none"> When system mode is stop, it turns ON When system mode changes from stop to other mode, it turns OFF 	OFF	R	UB64001	F00001
Pause mode	<ul style="list-style-type: none"> When system mode is pause, it turns ON When system mode changes from pause to other mode, it turns OFF 	OFF	R	UB64002	F00002
Debug mode	<ul style="list-style-type: none"> When system mode is debug, it turns ON When system mode changes from debug to other mode, it turns OFF 	OFF	R	UB64003	F00003

4.2.2 System signal

Name	Function	Initial value	R/W	GP device	LP device
Normally ON	<ul style="list-style-type: none"> When PLC mode is run, debug mode, it is normally ON When PLC mode is not run, debug mode, it is normally OFF 	OFF	R	UB64010	F00010
Normally OFF	<ul style="list-style-type: none"> When PLC mode is run, debug mode, it is normally OFF When PLC mode is not run, debug mode, it is normally ON 	OFF	R	UB64011	F00011
1 scan ON	<ul style="list-style-type: none"> When PLC mode is run, it turns ON only first one scan When PLC mode is run, it turns OFF after second scan 	OFF	R	UB64012	F00012
1 scan OFF	<ul style="list-style-type: none"> When PLC mode is run, it turns OFF only first one scan When PLC mode is run, it turns ON after second scan 	OFF	R	UB64013	F00013
Scan pulse	When PLC is in run mode, it reverses in every scan.	OFF	R	UB64014	F00014
Time synchronous pulse	One synchronous pulse during the RTC time.	OFF	R	UB64015	F00015

4.2.3 System status

Name	Function	Initial value	R/W	GP device	LP device
While operating forced input	<ul style="list-style-type: none"> When registering forced input device, it turns ON When releasing forced input device, it turns OFF 	OFF	R	UB64020	F00020
While operating forced output	<ul style="list-style-type: none"> When registering forced output device, it turns ON When releasing forced output device, it turns OFF 	OFF	R	UB64021	F00021
While running time-driven	<ul style="list-style-type: none"> When running time-driven, it turns ON When stopping time-driven, it turns OFF 	OFF	R	UB64024	F00024
Back-up battery errors(At present)	<ul style="list-style-type: none"> When the backup battery voltage is below the standard level, it turns ON When the backup battery voltage is over the standard level, it turns OFF 	OFF	R	UB6402C	F0002C
Back-up battery errors(Retaining)	<ul style="list-style-type: none"> When the backup battery voltage is below the standard level, it retains ON When changing program or mode, it turns OFF 	OFF	R	UB6402D	F0002D

4.2.4 System error

Name	Function	Initial value	R/W	GP device	LP device
Error occurrence	<ul style="list-style-type: none"> When any of errors occurs among the all defined errors, it turns ON. When clearing error, it turns OFF 	OFF	R	UB64030	F00030
Errors related to PLC program	<ul style="list-style-type: none"> When errors related to program occur, it turns ON. When clearing program error, it turns OFF When it stops operation, it turns OFF When changing program, it turns OFF When changing mode, it turns OFF 	OFF	R	UB64034	F00034
Time-driven operation error	<ul style="list-style-type: none"> When scan time is longer than time-driven setting time, it turns ON When scan time is shorter than time-driven setting time, it turns OFF 	OFF	R	UB64035	F00035

Name	Function	Initial value	R/W	GP device	LP device
Time setting error flag	<ul style="list-style-type: none"> When the time data is not properly written, it turns ON. When the time data is properly written by using RTC, it turns OFF. 	OFF	R	UB64036	F00036
Communication errors	<ul style="list-style-type: none"> When the communication error occurs, it turns ON. When the communication is properly completed, it turns OFF. 	OFF	R	UB64038	F00038
I/O setting value errors	<ul style="list-style-type: none"> Internal device range includes actual unavailable range, this bit turns ON when checking 'Using Internal Device' of 'I/O Contact Setting' dialog box in 'EXTENSION' tab from SmartStudio's Parameter. When user does not turn OFF, this bit maintains. 	OFF	R	UB64039	F00039

4.2.5 Module status

Name	Function	Initial value	R/W	GP device	LP device
Using inner device of SLOT 0	<ul style="list-style-type: none"> When SLOT0 parameter uses more than one inner device, it turns ON When SLOT0 parameter does not use inner device, it turns OFF 	OFF	R	UB64040	F00040
Using inner device of SLOT 1	<ul style="list-style-type: none"> When SLOT1 parameter uses more than one inner device, it turns ON When SLOT1 parameter does not use inner device, it turns OFF 	OFF	R	UB64041	F00041
Using inner device of SLOT 2	<ul style="list-style-type: none"> When SLOT2 parameter uses more than one inner device, it turns ON When SLOT2 parameter does not use inner device, it turns OFF 	OFF	R	UB64042	F00042
Using inner device of SLOT 3	<ul style="list-style-type: none"> When SLOT3 parameter uses more than one inner device, it turns ON When SLOT3 parameter does not use inner device, it turns OFF 	OFF	R	UB64043	F00043
Using inner device of SLOT 4	<ul style="list-style-type: none"> When SLOT4 parameter uses more than one inner device, it 	OFF	R	UB64044	F00044

Name	Function	Initial value	R/W	GP device	LP device
	turns ON • When SLOT4 parameter does not use inner device, it turns OFF				
Using inner device of SLOT 5	• When SLOT5 parameter uses more than one inner device, it turns ON • When SLOT5 parameter does not use inner device, it turns OFF	OFF	R	UB64045	F00045
Using inner device of SLOT 6	• When SLOT6 parameter uses more than one inner device, it turns ON • When SLOT6 parameter does not use inner device, it turns OFF	OFF	R	UB64046	F00046
Using inner device of SLOT 7	• When SLOT7 parameter uses more than one inner device, it turns ON • When SLOT7 parameter does not use inner device, it turns OFF	OFF	R	UB64047	F00047
Using inner device of SLOT 8	• When SLOT8 parameter uses more than one inner device, it turns ON • When SLOT8 parameter does not use inner device, it turns OFF	OFF	R	UB64048	F00048
Using inner device of SLOT 9	• When SLOT9 parameter uses more than one inner device, it turns ON • When SLOT9 parameter does not use inner device, it turns OFF	OFF	R	UB64049	F00049
Using inner device of SLOT 10	• When SLOT10 parameter uses more than one inner device, it turns ON • When SLOT10 parameter does not use inner device, it turns OFF	OFF	R	UB6404A	F0004A
Using inner device of SLOT 11	• When SLOT11 parameter uses more than one inner device, it turns ON • When SLOT11 parameter does not use inner device, it turns OFF	OFF	R	UB6404B	F0004B
Using inner device of SLOT 12	• When SLOT12 parameter uses more than one inner device, it turns ON • When SLOT12 parameter does not use inner device, it turns	OFF	R	UB6404C	F0004C

Name	Function	Initial value	R/W	GP device	LP device
	OFF				
Using inner device of SLOT 13	<ul style="list-style-type: none"> When SLOT13 parameter uses more than one inner device, it turns ON When SLOT13 parameter does not use inner device, it turns OFF 	OFF	R	UB6404D	F0004D
Using inner device of SLOT 14	<ul style="list-style-type: none"> When SLOT14 parameter uses more than one inner device, it turns ON When SLOT14 parameter does not use inner device, it turns OFF 	OFF	R	UB6404E	F0004E
Using inner device of SLOT 15	<ul style="list-style-type: none"> When SLOT15 parameter uses more than one inner device, it turns ON When SLOT15 parameter does not use inner device, it turns OFF 	OFF	R	UB6404F	F0004F

4.2.6 System clock

Name	Function	Initial value	R/W	GP device	LP device
10ms clock	10ms cycle of system clock occurs		R	UB64054	F00054
20ms clock	20ms cycle of system clock occurs		R	UB64055	F00055
50ms clock	50ms cycle of system clock occurs		R	UB64056	F00056
100ms clock	100ms cycle of system clock occurs		R	UB64057	F00057
200ms clock	200ms cycle of system clock occurs		R	UB64058	F00058
500ms clock	500ms cycle of system clock occurs		R	UB64059	F00059
1s clock	1s cycle of system clock occurs		R	UB6405A	F0005A
2s clock	2s cycle of system clock occurs		R	UB6405B	F0005B
5s clock	5s cycle of system clock occurs		R	UB6405C	F0005C
10s clock	10s cycle of system clock occurs		R	UB6405D	F0005D
60s clock	60s cycle of system clock occurs		R	UB6405E	F0005E

4.2.7 Operation

Name	Function	Initial value	R/W	GP device	LP device
Zero flag	<ul style="list-style-type: none"> When operation result is 0, it turns ON When operation result is not 0, it turns OFF 	OFF	R	UB64060	F00060
Carry flag	<ul style="list-style-type: none"> When carry occurs as operation result, it turns ON When carry does not occur as operation result, it turns OFF 	OFF	R	UB64061	F00061
Borrow flag	<ul style="list-style-type: none"> When borrow occurs as operation result, it turns ON When borrow does not occur as operation result, it turns OFF When changing program or mode, it turns OFF 	OFF	R	UB64062	F00062
Operation error flag(At present)	<ul style="list-style-type: none"> When operation error occurs during scan operation, it turns ON When changing the other mode except stop mode, it turns OFF When there is no operation error after one scan operation, it turns OFF When downloading program or re-setting power, it turns OFF 	OFF	R	UB64068	F00068
Operation error flag(Retaining)	<ul style="list-style-type: none"> When operation error occurs during scan operation, it retains ON When resetting power, it turns OFF 	OFF	R	UB64069	F00069

4.2.8 System setting

Name	Function	Initial value	R/W	GP device	LP device
Settings for full output restriction	<ul style="list-style-type: none"> When it turns ON, it is restricted port output and all ports becomes OFF. 	OFF	W	UB64070	F00070
Start-up time-driven activity	<ul style="list-style-type: none"> When it turns ON, it starts time-driven activity depending on a word setting value of time-driven run-time. When it turns OFF, it operates minimum speed of scan as possible as it can. 	OFF	W	UB64074	F00074
Operating conditions for extended module function	<ul style="list-style-type: none"> After checking 'Operating only in run mode' in 'COMMON' tab from SmartStudio's Parameter and downloading these, it turns RESET. After checking 'Operating in stop mode' in 'COMMON' tab from SmartStudio's Parameter and downloading these, it turns SET. In case of uploading from LP, it does not read data from parameter file, it is uploaded with the set contents from the special register. 	OFF	W	UB64078	F00078
Default filter setting flag	<ul style="list-style-type: none"> When it is set, operate all undefined filters of module in parameters as default values. When it is reset, all undefined filters of module are operated without a filter. 	OFF	W	UB64079	F00079

4.2.9 Time setting

Name	Function	Initial value	R/W	GP device	LP device
Time setting	<ul style="list-style-type: none"> Set it as a special register after it is ON. At this time, the time is not changed. When it turns OFF after completing settings, it is writing in RTC and the time set in the special register keeps going on. 	OFF	W	UB64080	F00080
+/- 30 sec correction of time setting	<ul style="list-style-type: none"> When it changes from OFF to ON within the range of 0 to 29sec, the time (second) is shifted to 00. When it changes from OFF to ON within the range of 30 to 59sec, the time(second) is shifted to 00 and increased one minute 	OFF	W	UB64081	F00081

4.2.10 Module setting

Name	Function	Initial value	R/W	GP device	LP device
Settings for using inner device of SLOT0 module function	When bit turns ON, inner device value is written to module register	OFF	W	UB64090	F00090
Settings for using inner device of SLOT1 module function	When bit turns ON, inner device value is written to module register	OFF	W	UB64091	F00091
Settings for using inner device of SLOT2 module function	When bit turns ON, inner device value is written to module register	OFF	W	UB64092	F00092
Settings for using inner device of SLOT3 module function	When bit turns ON, inner device value is written to module register	OFF	W	UB64093	F00093
Settings for using inner device of SLOT4 module function	When bit turns ON, inner device value is written to module register	OFF	W	UB64094	F00094
Settings for using inner device of SLOT5 module function	When bit turns ON, inner device value is written to module register	OFF	W	UB64095	F00095
Settings for using inner device of SLOT6 module function	When bit turns ON, inner device value is written to module register	OFF	W	UB64096	F00096
Settings for using inner device of SLOT7 module function	When bit turns ON, inner device value is written to module register	OFF	W	UB64097	F00097
Settings for using inner device of SLOT8 module function	When bit turns ON, inner device value is written to module register	OFF	W	UB64098	F00098
Settings for using inner device of SLOT9 module function	When bit turns ON, inner device value is written to module register	OFF	W	UB64099	F00099
Settings for using inner device of SLOT10 module function	When bit turns ON, inner device value is written to module register	OFF	W	UB6409A	F0009A
Settings for using inner device of SLOT11 module function	When bit turns ON, inner device value is written to module register	OFF	W	UB6409B	F0009B
Settings for using inner device of SLOT12 module function	When bit turns ON, inner device value is written to module register	OFF	W	UB6409C	F0009C
Settings for using inner device of SLOT13 module function	When bit turns ON, inner device value is written to module register	OFF	W	UB6409D	F0009D
Settings for using inner device of SLOT14 module function	When bit turns ON, inner device value is written to module register	OFF	W	UB6409E	F0009E
Settings for using	When bit turns ON, inner	OFF	W	UB6409F	F0009F

Name	Function	Initial value	R/W	GP device	LP device
inner device of SLOT15 module function	device value is written to module register				

4.2.11 Motion control

(1) CH1 special device

Name	Function	R/W	GP device	LP device
Using Motion CH1	<ul style="list-style-type: none"> • 1: Use • 0: No use 	R	UB64100	F100
Moving of Motion CH1 (Accel, decel, constant)	<ul style="list-style-type: none"> • 1: Moving • 0: Not moving 	R	UB64101	F101
Using acceleration of Motion CH1	<ul style="list-style-type: none"> • 1: Accelerating • 0: Not accelerating 	R	UB64102	F102
Driving with set speed of Motion CH1	<ul style="list-style-type: none"> • 1: Operating with set speed • 0: Not operating with set speed 	R	UB64103	F103
Decelerating of Motion CH1	<ul style="list-style-type: none"> • 1: Decelerating • 0: Not decelerating 	R	UB64104	F104
Dwelling of Motion CH1	<ul style="list-style-type: none"> • 1: Dwelling • 0: Not dwelling 	R	UB64105	F105
Finish driving of CH1	<ul style="list-style-type: none"> • 1: Finishing drive • 0: Not finishing drive 	R	UB64106	F106
Detecting S/W lower limit of Motion CH1	<ul style="list-style-type: none"> • 1: Detecting S/W lower limit • 0: Not detecting S/W lower limit 	R	UB64107	F107
Detecting S/W upper limit of Motion CH1	<ul style="list-style-type: none"> • 1: Detecting S/W upper limit • 0: Not detecting S/W upper limit 	R	UB64108	F108
Detecting H/W lower limit of Motion CH1	<ul style="list-style-type: none"> • 1: Detecting H/W upper limit • 0: Not detecting H/W upper limit 	R	UB64109	F109
Detecting H/W upper limit of Motion CH1	<ul style="list-style-type: none"> • 1: Detecting H/W lower limit • 0: Not detecting H/W lower limit 	R	UB6410A	F10A

(2) CH2 special device

Name	Function	R/W	GP device	LP device
Using Motion CH2	<ul style="list-style-type: none"> • 1: Use • 0: No use 	R	UB64120	F120
Moving of Motion CH2 (Accel, decel, constant)	<ul style="list-style-type: none"> • 1: Moving • 0: Not moving 	R	UB64121	F121
Using acceleration of Motion CH2	<ul style="list-style-type: none"> • 1: Accelerating • 0: Not accelerating 	R	UB64122	F122
Driving with set speed of Motion CH2	<ul style="list-style-type: none"> • 1: Operating with set speed • 0: Not operating with set speed 	R	UB64123	F123
Decelerating of Motion CH2	<ul style="list-style-type: none"> • 1: Decelerating • 0: Not decelerating 	R	UB64124	F124
Dwelling of Motion CH2	<ul style="list-style-type: none"> • 1: Dwelling 	R	UB64125	F125

Name	Function	R/W	GP device	LP device
	<ul style="list-style-type: none"> 0: Not dwelling 			
Finish driving of CH2	<ul style="list-style-type: none"> 1: Finishing drive 0: Not finishing drive 	R	UB64126	F126
Detecting S/W lower limit of Motion CH2	<ul style="list-style-type: none"> 1: Detecting S/W lower limit 0: Not detecting S/W lower limit 	R	UB64127	F127
Detecting S/W upper limit of Motion CH2	<ul style="list-style-type: none"> 1: Detecting S/W upper limit 0: Not detecting S/W upper limit 	R	UB64128	F128
Detecting H/W lower limit of Motion CH2	<ul style="list-style-type: none"> 1: Detecting H/W upper limit 0: Not detecting H/W upper limit 	R	UB64129	F129
Detecting H/W upper limit of Motion CH2	<ul style="list-style-type: none"> 1: Detecting H/W lower limit 0: Not detecting H/W lower limit 	R	UB6412A	F12A

(3) Jog special device

Name	Function	R/W	GP device	LP device
Jog starting forward of Motion CH1	<ul style="list-style-type: none"> ON rising: Moving forward jog in accelerating and constant speed OFF falling: Moving forward jog in decelerating and stop 	R/W	UB64501	F501
Jog starting backward of Motion CH1	<ul style="list-style-type: none"> ON rising: Moving backward jog in accelerating and constant speed OFF falling: Moving backward jog in decelerating and stop 	R/W	UB64502	F502
Jog starting forward of Motion CH2	<ul style="list-style-type: none"> ON rising: Moving forward jog in accelerating and constant speed OFF falling: Moving forward jog in decelerating and stop 	R/W	UB64503	F503
Jog starting backward of Motion CH2	<ul style="list-style-type: none"> ON rising: Moving backward jog in accelerating and constant speed OFF falling: Moving backward jog in decelerating and stop 	R/W	UB64504	F504

4.3 Word special device

4.3.1 PLC model

Name	Function	R/W	GP device	LP device
PLC series and model code	<ul style="list-style-type: none"> • High 2 digits = Series code • Low 2 digits = Model code 	R	UW6500	F0100
System version	Displays the version of firmware by the range of 5 word	R	UW6501 to UW6505	F0101 to F0105
Released date of the version(Year)	Released year of the version	R	UW6506	F0106
Released date of the version(Month, date)	Released month and date of the version. Displays 4 digits, high 2 digits denotes month and low 2 digits denotes date.	R	UW6507	F0107

4.3.2 Scan time

Name	Function	R/W	GP device	LP device
Present scan time	Executing time for present scan (Revised in every scan)	R	UW6510	F0110
Min. scan time	Min. scan time during the operation(It clears when changing PLC mode or program)	R	UW6511	F0111
Max. scan time	Max. scan time during the operation(It clears when changing PLC mode or program)	R	UW6512	F0112
Average scan time	Displays average scan time	R	UW6513	F0113

4.3.3 Operation

Name	Function	R/W	GP device	LP device
Step operation generated error (At present)	Present step which has operation error (It clears when changing PLC mode or program)	R	UW6520	F0120
Step operation generated error (Retaining)	First operation error step, (It clears when changing PLC mode or program)	R	UW6521	F0121

4.3.4 Step

Name	Function	R/W	GP device	LP device
Error step	Stopped step by error at present	R	UW6530	F0130
Break step	Braked step during debug mode operation (It clears when changing PLC mode or program)	R	UW6531	F0131

4.3.5 Diagnosis

Name	Function	R/W	GP device	LP device
Self-diagnosis error code	Displays self-diagnosis error code	R	UW6540	F0140

UW6540(F0140)	Type	Cause of error
0X0010	Watchdog error	Scan time exceeds watchdog timer setting value
0X0020	Memory error	When a certain area of memory is the un-approached state.
0x0021	Battery error	When battery value is below the standard level
0x0022	RTC setting error	Disable to set RTC and RTC operation error
0X0030	Program instruction error	When the program contains instructions that are not able to read and inappropriate forms.
0X0031	Program sequence error	When there is not the instructions required to process the program, such as user defined functions, label name, END, RET and IRET, etc.
0X0040	Parameter setting error	When there are some problems in settings for common and expansion parameters.
0X0041	Time-driven error	When it operates longer than the given time-driven run-time.
0X0050	Extended module setting error	In case the hardware constructions are different from previous parameter settings when applying power again and changing the mode.
0X0051	Extended module attaching and removing error	When the extended module is attached or removed in run mode.
0x0060	Communication fail error	When it is received NAK and data format not able to read.
0x0061	Communication format error	When there are some problems occurred in formats (excess of limited range etc.) and CHECK SUM while download and upload.

4.3.6 Time

Name	Function	R/W	GP device	LP device
Time setting (Year)	Save the setting value of year as BCD Data	W	UW6550	F0150
Time setting (Month)	Save the setting value of month as BCD Data	W	UW6551	F0151
Time setting (Date)	Save the setting value of date as BCD Data	W	UW6552	F0152
Time setting (Hour)	Save the setting value of hour as BCD Data	W	UW6553	F0153
Time setting (Min)	Save the setting value of minute as BCD Data	W	UW6554	F0154
Time setting (Sec)	Save the setting value of second as BCD Data	W	UW6555	F0155
Time setting (Day)	Save the setting value of the day of week as BCD Data	W	UW6556	F0156

Name	Function	R/W	GP device	LP device
	0: Sunday, 1: Monday, 2: Tuesday, 3: Wednesday, 4: Thursday, 5: Friday, 6: Saturday			

4.3.7 Input filter setting

Name	Function	R/W	GP device	LP device
Input filter settings	Designates default input filter value by ms unit When this is 0, it does not set filter value. It applies to all of non-filter setting modules.	R/W	UW6560	F0160

4.3.8 Time-driven run-time settings

Name	Function	R/W	GP device	LP device
Time-driven run-time settings	When time-driven setting flag is ON, time-driven running operates with the setting time of this register.	R/W	UW6561	F0161
Watchdog timer settings	0 to 65535 (Unit: ms)	R/W	UW6562	F0162

4.3.9 Time-driven interrupt

Name	Function	R/W	GP device	LP device
Time-driven interrupt cycle settings 1	Time-driven interrupt cycle settings 1	R/W	UW6570	F0170
Time-driven interrupt cycle settings 2	Time-driven interrupt cycle settings 2	R/W	UW6571	F0171
Time-driven interrupt cycle settings 3	Time-driven interrupt cycle settings 3	R/W	UW6572	F0172
Time-driven interrupt cycle settings 4	Time-driven interrupt cycle settings 4	R/W	UW6573	F0173
Time-driven interrupt cycle settings 5	Time-driven interrupt cycle settings 5	R/W	UW6574	F0174
Time-driven interrupt cycle settings 6	Time-driven interrupt cycle settings 6	R/W	UW6575	F0175
Time-driven interrupt cycle settings 7	Time-driven interrupt cycle settings 7	R/W	UW6576	F0176
Time-driven interrupt cycle settings 8	Time-driven interrupt cycle settings 8	R/W	UW6577	F0177

4.3.10 Motion control

(1) CH1 special device

Name	Function	R/W	GP device	LP device
Current position	Current position of Motion CH1	R	UW6460	F60
Current speed	Current speed of Motion CH1	R	UW6462	F62
Action No.	Current action No. of Motion CH1	R	UW6464	F64
Pattern No.	Current pattern No. of Motion CH1	R	UW6465	F65
Home position	Current home position of Motion CH1	R	UW6466	F66
Set speed	Setting speed of Motion CH1	R	UW6468	F68
Error check	Error code check of Motion CH1	R	UW6420	F20

(2) CH2 special device

Name	Function	R/W	GP device	LP device
Current position	Current position of Motion CH2	R	UW6470	F70
Current speed	Current speed of Motion CH2	R	UW6472	F72
Action No.	Current action No. of Motion CH2	R	UW6474	F74
Pattern No.	Current pattern No. of Motion CH2	R	UW6475	F75
Home position	Current home position of Motion CH2	R	UW6476	F76
Set speed	Setting speed of Motion CH2	R	UW6478	F78
Error check	Error code check of Motion CH2	R	UW6421	F21

5 Appendix

5.1 Error code and how to manage it

(1) Self-diagnosis error code

UW6540(F0140)	Type	Cause of error
0X0010	Watchdog error	Scan time exceeds watchdog timer setting value
0X0020	Memory error	When a certain area of memory is the un-approached state.
0x0021	Battery error	When battery value is below the standard level
0x0022	RTC setting error	Disable to set RTC and RTC operation error
0X0030	Program instruction error	When the program contains instructions that are not able to read and inappropriate forms.
0X0031	Program sequence error	When there is not the instructions required to process the program, such as user defined functions, label name, END, RET and IRET, etc.
0X0040	Parameter setting error	When there are some problems in settings for common and expansion parameters.
0X0041	Time-driven error	When it operates longer than the given time-driven run-time.
0X0050	Extended module setting error	In case the hardware constructions are different from previous parameter settings when applying power again and changing the mode.
0X0051	Extended module attaching and removing error	When the extended module is attached or removed in run mode.
0x0060	Communication fail error	When it is received NAK and data format not able to read.
0x0061	Communication format error	When there are some problems occurred in formats (excess of limited range etc.) and CHECK SUM while download and upload.

(1) Motion error code

UW6420, UW6421	Symptom	Run state	Troubleshooting
1	When inputting other starting instruction signal during using channel	Run	Clear the error by MTMEC(removing error) instruction and executes next start instruction
2	When giving progress instruction to other direction than current progressing direction during consecutive running 'C'	Stop	Edit the pattern list which has problem. Clear the error by MTMEC(removing error) instruction and executes motion operation
3	When setting position preset during running	Run	Clear the error by MTMEC(removing error) instruction
4	When there is no action list to operate during executing pattern action	Stop	Edit the action list which has problem. Clear the error by MTMEC(removing error) instruction
5	When action list type is position drive during executing	Stop	Check and edit action list and S/W limit value which have problem. Clear

UW6420, UW6421	Symptom	Run state	Troubleshooting
	pattern action and destination position is out of S/W limit range		the error by MTMEC(removing error) instruction
10	Excess high low limit error	Stop	Clear the error by MTMEC(removing error) instruction and escape limit with jog operation and execute the next
20	When speed parameter value is higher than maximum speed (100,000PPS) Designated pattern number of MTIDM(Indirect designated drive) instruction is out of 1 to 99	Stop	Clear the error by MTMEC(removing error) instruction and check the set parameter values

※1. Be sure that errors related with motion are remained even if restarting LP.

5.2 Instruction execution time list

5.2.1 Basic instruction

Instruction	Step	Operand	Execution time(ON/OFF) (Unit: us)	
			LP-S044	LP-S070
LOAD	1	1	10.625	2.5
LOADN	1	1	10.25	2.5
LOADP	2	1	19.8	5
LOADF	2	1	19.8	5
AND	1	1	10.3	2.5
ANDN	1	1	10.5	2.5
ANDP	2	1	20.28	5
ANDF	2	1	20.28	5
OR	1	1	10	2.5
ORN	1	1	10	2.5
ORP	2	1	19	5
ORF	2	1	19	5
OUT	1	1	10.625	2.5
OUTP	2	1	18.4	5
OUTF	2	1	18.4	5
ALT	3	1	28.12 / 25.0	4.125
SET	1	1	10	2.5

5.2.2 Timer/Counter instruction

Instruction	Step	Operand	Execution time(ON/OFF) (Unit: us)	
			LP-S044	LP-S070
CTD	5	2	29.5	8.75
CTU	5	2	29.5	8.75
CTUD	5	2	32.0	9.375
CTR	5	2	29.5	8.75
TON	5	2	28.5	8.75
TOFF	5	2	27.5	8.125
TMR	5	2	27.5	7.5
TMON	5	2	27.5	8.125
TRTG	5	2	739.0	8.75

5.2.3 Input comparison instruction

Instruction	Step	Operand	Execution time(ON/OFF) (Unit: us)	
			LP-S044	LP-S070
LOAD=	5	2	26.87	8.125
LOAD>	5	2	26.87	8.75
LOAD<	5	2	26.87	8.75
LOAD<>	5	2	26.87	8.75
LOAD>=	5	2	26.87	8.75
LOAD<=	5	2	26.87	8.75
DLOAD=	5	2	29.0	8.125
DLOAD>	5	2	29.0	8.75
DLOAD<	5	2	29.0	8.75
DLOAD<>	5	2	29.0	8.75
DLOAD>=	5	2	29.0	9.375
DLOAD<=	5	2	29.0	9.375
AND=	5	2	28.5	10
AND>	5	2	28.5	10
AND<	5	2	28.5	10
AND<>	5	2	28.5	10.625
AND>=	5	2	28.5	10.625
AND<=	5	2	28.5	10.625
DAND=	5	2	29.5	10.625
DAND>	5	2	29.5	10.625
DAND<	5	2	29.5	10.625
DAND<>	5	2	29.5	10.625
DAND>=	5	2	29.5	10.635
DAND<=	5	2	29.5	10.625
OR=	5	2	28.0	10.625
OR>	5	2	28.0	10.625
OR<	5	2	28.0	10.625
OR<>	5	2	28.0	10.625
OR>=	5	2	28.0	10.625
OR<=	5	2	28.0	10.625
DOR=	5	2	29.0	10.625
DOR>	5	2	29.0	10.625
DOR<	5	2	29.0	10.625
DOR<>	5	2	29.0	10.625
DOR>=	5	2	29.0	10.625
DOR<=	5	2	29.0	10.625

5.2.4 Comparison instruction

Instruction	Step	Operand	Execution time(ON/OFF) (Unit: us)	
			LP-S044	LP-S070
CMP	7	3	49.35 / 34.3	11.375
DCMP	7	3	51.1 / 35.35	12.25
ACMP	7	4	If H: 3, it is 54.6 If H: 15, it is 74.2 If H: 30, it is 94.5 If non-execution, it is 39.2	If H: 3, it is 16.625 If H: 15, it is 17.5 If H: 30, it is 21 If non-execution, it is 16.625
CMPL	9	4	If N: 2, it is 62.1 If N: 4, it is 85.5 If N: 8, it is 124.2 If N: 16, it is 211.5 If non-execution, it is 41.85	If N: 2, it is 18 If N: 4, it is 21.375 If N: 8, it is 29.25 If N: 16, it is 45 If non-execution, it is 13.5
DCMPL	9	4	If N: 2, it is 66.6 If N: 4, it is 88.2 If N: 8, it is 129.6 If N: 16, it is 214.2 If non-execution, it is 43.2	If N: 2, it is 22.5 If N: 4, it is 25.875 If N: 8, it is 32.625 If N: 16, it is 39.375 If non-execution, it is 15.75

5.2.5 Transmission instruction

Instruction	Step	Operand	Execution time(ON/OFF) (Unit: us)	
			LP-S044	LP-S070
BMOV	5	2	19.5 / 19.5	6.875
MOV	5	2	19.5 / 19.5	7.5
DMOV	5	2	22.35 / 22.35	8.75
BMOVL	7	3	If N: 2, it is 35 If N: 4, it is 37.8 If N: 8, it is 44.1 If N: 16, it is 56 If non-execution, it is 32.9	If N: 2, it is 13.125 If N: 4, it is 16.625 If N: 8, it is 20.125 If N: 16, it is 16.625 If non-execution, it is 9.625
MOVL	7	3	If N: 2, it is 29.4 If N: 4, it is 31.5 If N: 8, it is 33.6 If N: 16, it is 37.8 If non-execution, it is 27.3	If N: 2, it is 9.625 If N: 4, it is 12.25 If N: 8, it is 13.125 If N: 16, it is 15.75 If non-execution, it is 9.625
DMOVL	7	3	If N: 2, it is 33.32 If N: 4, it is 35.35 If N: 8, it is 38.5 If N: 16, it is 45.5 If non-execution, it is 31.5	If N: 2, it is 10.5 If N: 4, it is 12.25 If N: 8, it is 14 If N: 16, it is 18.375 If non-execution, it is 9.625
BMOVG	7	3	If N: 2, it is 37.1 If N: 4, it is 41.6 If N: 8, it is 449.7 If N: 16, it is 65.8 If non-execution, it is 32.9	If N: 2, it is 12.25 If N: 4, it is 13.125 If N: 8, it is 16.625 If N: 16, it is 18.375 If non-execution, it is

Instruction	Step	Operand	Execution time(ON/OFF) (Unit: us)	
			LP-S044	LP-S070
				11.375
MOVG	7	3	If N: 2, it is 27.3 If N: 4, it is 28.35 If N: 8, it is 30.1 If N: 16, it is 37.1 If non-execution, it is 26.6	If N: 2, it is 10.5 If N: 4, it is 11.375 If N: 8, it is 13.125 If N: 16, it is 15.75 If non-execution, it is 9.625
DMOVG	7	3	If N: 2, it is 28.35 If N: 4, it is 30.38 If N: 8, it is 33.32 If N: 16, it is 39.2 If non-execution, it is 26.6	If N: 2, it is 10.5 If N: 4, it is 11.375 If N: 8, it is 13.125 If N: 16, it is 14 If non-execution, it is 8.75

5.2.6 Rotation instruction

Instruction	Step	Operand	Execution time(ON/OFF) (Unit: us)	
			LP-S044	LP-S070
ROR	5	2	25.5 / 21.5	8.125
DROR	5	2	25.5 / 21.5	8.125
RORC	5	2	27 / 21.5	8.75
DRORC	5	2	27 / 21.5	8.75
ROL	5	2	25.5 / 21.5	8.125
DROL	5	2	25.5 / 21.5	8.125
ROLC	5	2	27 / 21.5	8.75
DROLC	5	2	27 / 21.5	8.75

5.2.7 Movement instruction

Instruction	Step	Operand	Execution time(ON/OFF) (Unit: us)	
			LP-S044	LP-S070
ASFTR	9	3	43.2 / 35.55	12.375
ASFTL	9	3	43.2 / 35.55	12.375
WSFTR	9	3	If N1: 8, it is 40.5 If N1: 16, it is 45.5 If N1: 24, it is 50.4 If N1: 32, it is 54 If non-execution, it is 33.3	If N1: 8, it is 12.375 If N1: 16, it is 13.5 If N1: 24, it is 14.625 If N1: 32, it is 15.75 If non-execution, it is 11.25
WSFTL	9	3	If N1: 8, it is 40.5 If N1: 16, it is 45.5 If N1: 24, it is 50.4 If N1: 32, it is 54 If non-execution, it is 33.3	If N1: 8, it is 12.375 If N1: 16, it is 12.375 If N1: 24, it is 14.625 If N1: 32, it is 15.75 If non-execution, it is 11.25

5.2.8 Arithmetic operation instruction

Instruction	Step	Operand	Execution time(ON/OFF) (Unit: us)	
			LP-S044	LP-S070
ADD	7	3	37.1 / 32.2	11.375
DADD	7	3	52.36 / 38.36	13.125
ADDU	7	3	37.1 / 32.2	12.25
DADDU	7	3	52.36 / 38.36	14
SUB	7	3	37.1 / 32.2	11.375
DSUB	7	3	40.32 / 36.33	12.25
SUBU	7	3	37.1 / 32.2	11.375
DSUBU	7	3	40.32 / 36.33	12.25
MUL	7	3	37.1 / 32.2	12.25
DMUL	7	3	53.34 / 38.36	14
MULU	7	3	37.1 / 32.2	12.25
DMULU	7	3	53.34 / 38.36	14.875
DIV	7	3	46.2 / 34.3	13.125
DDIV	7	3	52.36 / 38.36	14
DIVU	7	3	46.2 / 34.3	13.125
DDIVU	7	3	52.36 / 38.36	13.125
INC	3	1	13.8 / 12.3	4.875
DINC	3	1	14.37 / 12.87	4.875
DEC	3	1	13.8 / 12.3	4.875
DDEC	3	1	14.37 / 12.87	4.875
ADDB	7	3	67.2 / 32.2	13.125
DADDB	7	3	110.32 / 35.35	14
SUBB	7	3	41.3 / 32.2	13.125
DSUBB	7	3		14
MULB	7	3	95.2 / 32.2	13.125
DMULB	7	3		21
DIVB	7	3	82.6 / 32.2	14
DDIVB	7	3		14
INCB	3	1	39.9 / 12.9	6
DINCB	3	1		7.5
DECB	3	1	39.9 / 12.9	6
DDECB	3	1		6.375

5.2.9 Exchange instruction

Instruction	Step	Operand	Execution time(ON/OFF) (Unit: us)	
			LP-S044	LP-S070
XCH	5	2	19.5 / 18.0	6.875
DXCH	5	2	20.1 / 18.0	7.5
SWAP	3	1	12.9 / 11.9	4.5
DSWAP	3	1	13.35 / 12.3	4.875

5.2.10 Motion instruction

Instruction	Step	Operand	Execution time(ON/OFF) (Unit: us)
			LP-S070
MTVDM	9	6	15.75
MTPDM	9	6	18
MTIDM	5	2	9
MTIPT	7	4	13.5
MTUAI	5	2	11.25
MTMEC	5	1	6.75
MTEMS	5	1	9
MTCPP	5	2	9
MTFOS	5	1	6.75
MTSRS	5	1	6.75
MTOBC	5	1	6.75
MTOVV	5	2	9
MTOVP	5	2	10.125







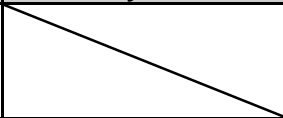



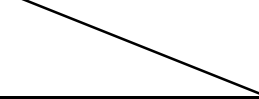

5.3 Instruction

5.3.1 Basic instruction list





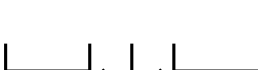

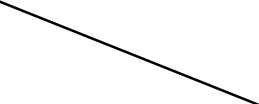
5.3.1.1 Non processing instruction

Instruction	Ladder symbol	Step
NOP		1



5.3.1.2 Contact instruction

Instruction	Ladder symbol	Step	Instruction	Ladder symbol	Step
LOAD		1	ANDF		2
LOADN		1	ANDL		1
LOADP		2	OR		1
LOADF		2	ORN		1
AND		1	ORP		2
ANDN		1	ORF		2
ANDP		2	ORL		1

5.3.1.3 Output instruction

Instruction	Ladder symbol	Step	Instruction	Ladder symbol	Step
OUT		1	SET		1
OUT Syyy.xx		1	SET Syyy.xx		1
OUTP		2	RST		1
OUTF		2			

5.3.1.4 Reversal instruction

Instruction	Ladder symbol	Step	Instruction	Ladder symbol	Step
ALT		3	NOT		1

5.3.1.5 Stack instruction

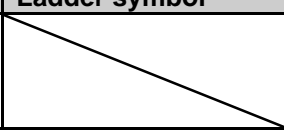
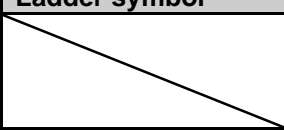
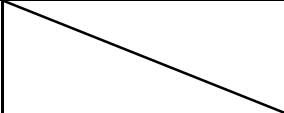

Instruction	Ladder symbol	Step	Instruction	Ladder symbol	Step
MPUSH		1	MPOP		1
MLOAD		1			

5.3.1.6 Exit instruction



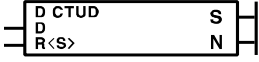

Instruction	Ladder symbol	Step
END		1

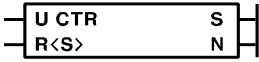
5.3.2 Application instruction list



5.3.2.1 Counter instruction

Instruction	Ladder symbol	Step	Instruction	Ladder symbol	Step
CTU		5	CTUD		5
CTD		5	CTR		5



5.3.2.2 Timer instruction

Instruction	Ladder symbol	Step	Instruction	Ladder symbol	Step
TON		5	TMON		5
TOFF		5	TRTG		5
TMR		5			

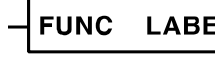

5.3.2.3 Control instruction

Instruction	Ladder symbol	Step	Instruction	Ladder symbol	Step
JMP		3	FCALL		3
LABEL		3	FUNC		3

5.3.2.4 Branch instruction

Instruction	Ladder symbol	Step	Instruction	Ladder symbol	Step
CALL		3	RET		1
SUBRT		3			





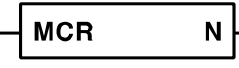

5.3.2.5 Loop instruction

Instruction	Ladder symbol	Step	Instruction	Ladder symbol	Step
FOR		3	BREAK		1
NEXT		1			

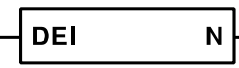
5.3.2.6 Master control instruction

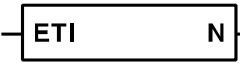
Instruction	Ladder symbol	Step	Instruction	Ladder symbol	Step
MCS		2	MCR		2

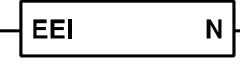

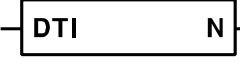







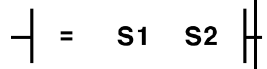





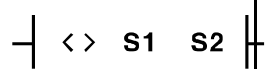
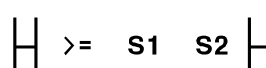
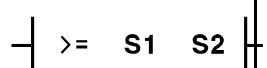
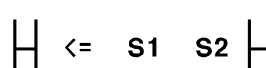
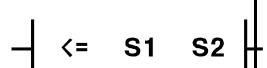

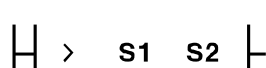
5.3.2.7 Interrupt instruction

Instruction	Ladder symbol	Step	Instruction	Ladder symbol	Step
EI		1	DEI		1
DI		1	TINT		1
ETI		1	EINT		1
E EI		1	IRET		1
DTI		1			

5.3.2.8 Watchdog timer

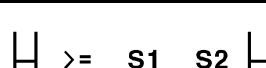
Instruction	Ladder symbol	Step
WDT		1

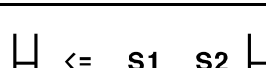
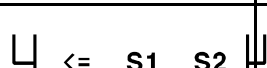
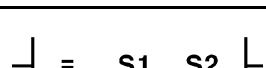
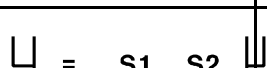
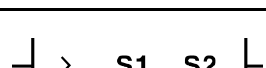
5.3.2.9 Input comparison instruction

Instruction	Ladder symbol	Step	Instruction	Ladder symbol	Step
LOAD=		5	DAND=		5
LOAD>		5	DAND>		5
LOAD<		5	DAND<		5
LOAD<>		5	DAND<>		5
LOAD>=		5	DAND>=		5
LOAD<=		5	DAND<=		5
DLOAD=		5	OR=		5
DLOAD>		5	OR>		5
DLOAD<		5	OR<		5
DLOAD<>		5	OR<>		5
DLOAD>=		5	OR>=		5
DLOAD<=		5	OR<=		5
AND=		5	DOR=		5
AND>		5	DOR>		5
AND<		5	DOR<		5

Instruction	Ladder symbol	Step	Instruction	Ladder symbol	Step
AND<>		5	DOR<>		5
AND>=		5	DOR>=		5
AND<=		5	DOR<=		5





5.3.2.10 Comparison instruction

Instruction	Ladder symbol	Step	Instruction	Ladder symbol	Step
CMP		7	DCMPL		9
DCMP		7	BWCMP		9
ACMP		7	DBWCMP		9
CMPL		9			

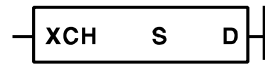

5.3.2.11 Transmission instruction

Instruction	Ladder symbol	Step	Instruction	Ladder symbol	Step
BMOV		5	BMOVG		7
MOV		5	MOVG		7
DMOV		5	DMOVG		7
BMOVL		7	BCMOV		5
MOVL		7	CMOV		5
DMOVL		7	DCMOV		5

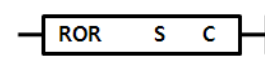
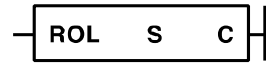
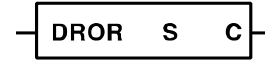
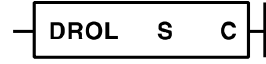

5.3.2.12 Exchange instruction

Instruction	Ladder symbol	Step	Instruction	Ladder symbol	Step
XCH		5	SWAP		3
DXCH		5	DSWAP		3
AXCH		7			

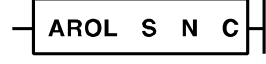
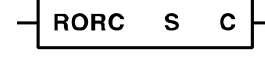
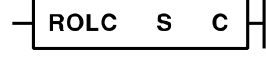
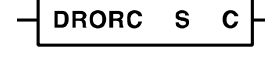
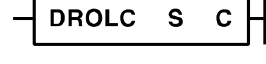
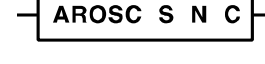
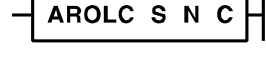
5.3.2.13 Rotation instruction

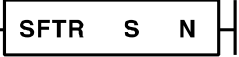
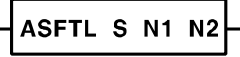

Instruction	Ladder symbol	Step	Instruction	Ladder symbol	Step
ROR		5	ROL		5
DROR		5	DROL		5
AROR		7	AROL		7
RORC		5	ROLC		5
DRORC		5	DROLC		5
ARORC		7	AROLC		7

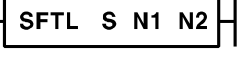
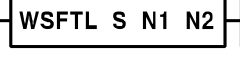

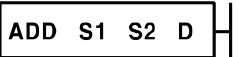
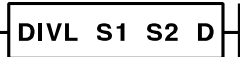
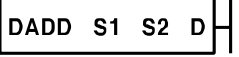
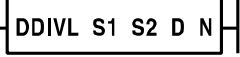
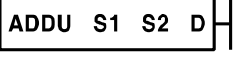
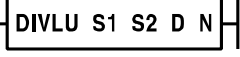
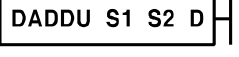
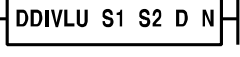
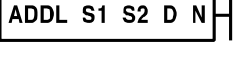
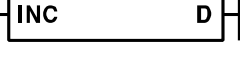
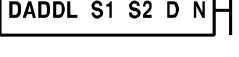
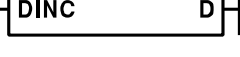
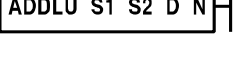
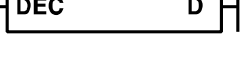
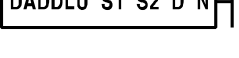
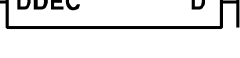
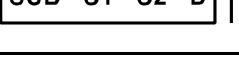
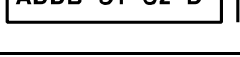
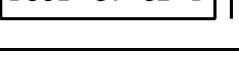
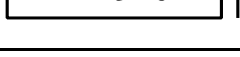
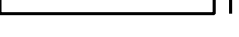
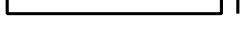

5.3.2.14 Movement instruction

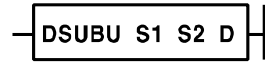
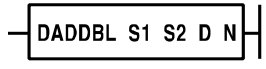
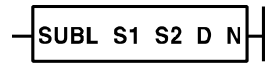
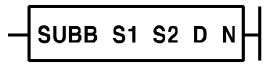
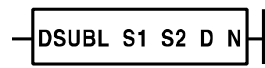
Instruction	Ladder symbol	Step	Instruction	Ladder symbol	Step
SFTR		9	ASFTL		9
ASFTR		9	WSFTR		9
SFTL		9	WSFTL		9

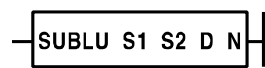
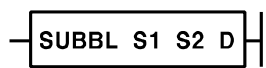
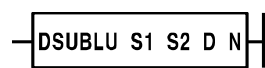
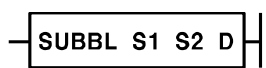
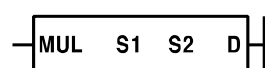
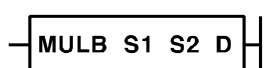
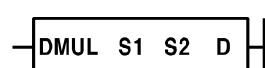
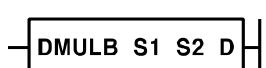
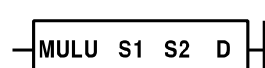
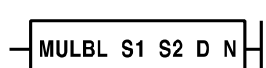
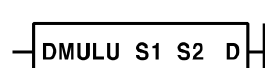
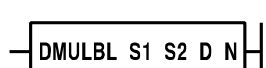
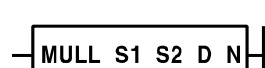
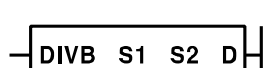
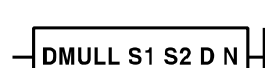
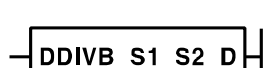
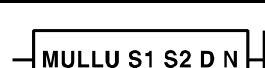
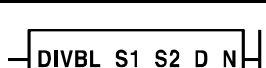
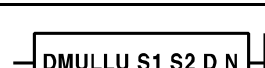
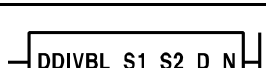
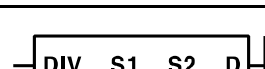
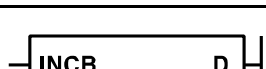
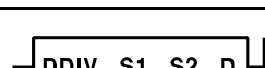
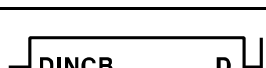
5.3.2.15 Arithmetic operation instruction

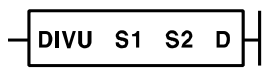
Instruction	Ladder symbol	Step	Instruction	Ladder symbol	Step
ADD		7	DIVL		9
DADD		7	DDIVL		9
ADDU		7	DIVLU		9
DADDU		7	DDIVLU		9
ADDL		9	INC		3
DADDL		9	DINC		3
ADDLU		9	DEC		3
DADDLU		9	DDEC		3
SUB		7	ADDB		7
DSUB		7	DADDB		7
SUBU		7	ADDBL		9

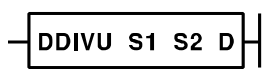

Instruction	Ladder symbol	Step	Instruction	Ladder symbol	Step
DSUBU		7	DADDBL		9
SUBL		9	SUBB		7
DSUBL		9	DSUBB		7
SUBLU		9	SUBBL		9
DSUBLU		9	DSUBBL		9
MUL		7	MULB		7
DMUL		7	DMULB		7
MULU		7	MULBL		9
DMULU		7	DMULBL		9
MULL		9	DIVB		7
DMULL		9	DDIVB		7
MULLU		9	DIVBL		9
DMULLU		9	DDIVBL		9
DIV		7	INCB		3
DDIV		7	DINCB		3

Instruction	Ladder symbol	Step	Instruction	Ladder symbol	Step
DIVU		7	DECB		3
DDIVU		7	DDECB		3

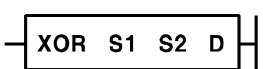
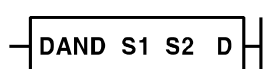
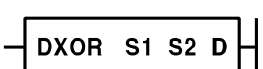
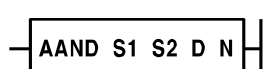
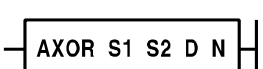
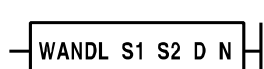
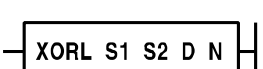
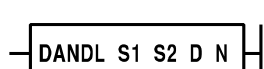
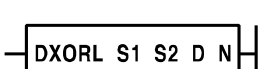
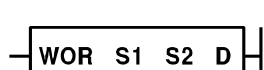
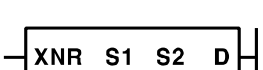
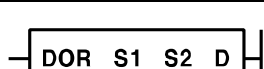
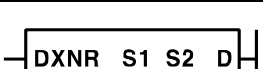
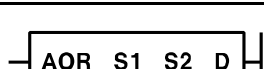
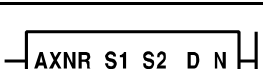
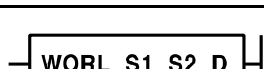
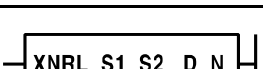
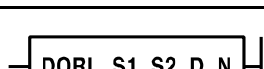
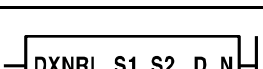

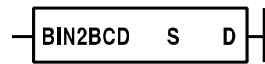
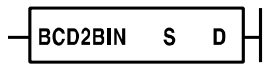

5.3.2.16 Logical operation instruction

Instruction	Ladder symbol	Step	Instruction	Ladder symbol	Step
WAND		7	XOR		7
DAND		7	DXOR		7
AAND		9	AXOR		9
WANDL		9	XORL		9
DANDL		9	DXORL		9
WOR		7	XNR		7
DOR		7	DXNR		7
AOR		9	AXNR		9
WORL		9	XNRL		9
DORL		9	DXNRL		9



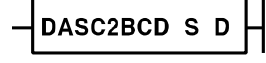
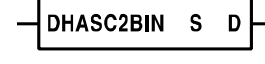
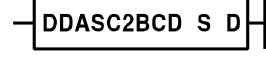
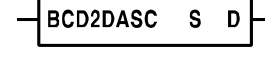
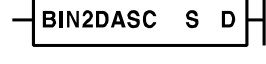
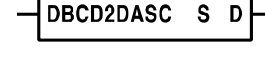
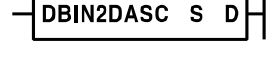
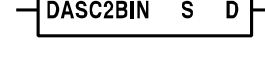

5.3.2.17 BIN/BCD instruction

Instruction	Ladder symbol	Step	Instruction	Ladder symbol	Step
BIN2BCD		5	BCD2BIN		5
DBIN2BCD		5	DBCD2BIN		5

5.3.2.18 String conversion instruction

Instruction	Ladder symbol	Step	Instruction	Ladder symbol	Step
BIN2HASC		5	DDASC2BIN		5
DBIN2HASC		5	STR2ASC		7
HASC2BIN		5	DASC2BCD		5
DHASC2BIN		5	DDASC2BCD		5
BCD2DASC		5	BIN2DASC		5
DBCD2DASC		5	DBIN2DASC		5
DASC2BIN		5			

5.3.2.19 Code conversion instruction

Instruction	Ladder symbol	Step	Instruction	Ladder symbol	Step
GRY2BIN		5	BIN2GRY		5
DGRY2BIN		5	DBIN2GRY		5

5.3.2.20 Sign reverse instruction

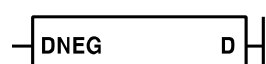
Instruction	Ladder symbol	Step	Instruction	Ladder symbol	Step
NEG		3	DNEG		3

5.3.2.21 Data conversion instruction

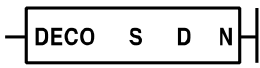
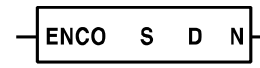
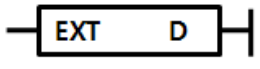
Instruction	Ladder symbol	Step	Instruction	Ladder symbol	Step
DECO		7	ENCO		7
EXT		3			



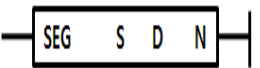

5.3.2.22 Refresh instruction

Instruction	Ladder symbol	Step
REF		5

5.3.2.23 Display instruction

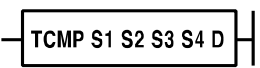
Instruction	Ladder symbol	Step
SEG		7

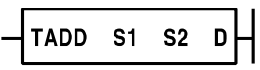
5.3.2.24 Clock instruction

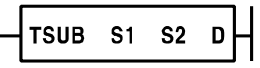
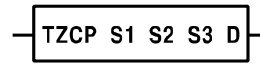
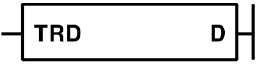
Instruction	Ladder symbol	Step	Instruction	Ladder symbol	Step
TCMP		7	TWR		3
TADD		7	HOUR		7
TSUB		7	TZCP		9
TRD		3			

5.3.2.25 Motion Instruction

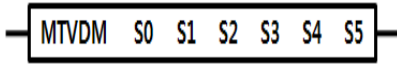
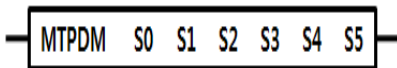
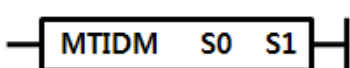
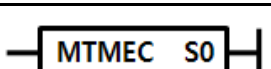
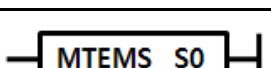
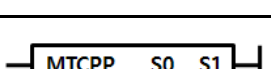
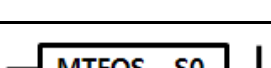
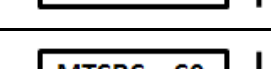
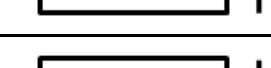
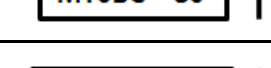
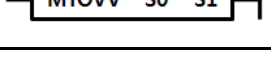
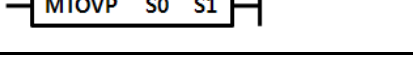
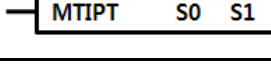
Instruction	Ladder symbol	Step
MTVDM		9
MTPDM		9
MTIDM		5
MTMEC		5
MTEMS		5
MTCPP		5
MTFOS		5
MTSRS		5
MTOBC		5
MTOVV		5
MTOVP		5
MTIPT		7
MTUAI		5

5.3.3 Structures of instruction name

The structure of instruction name is divided into three parts and each part represents data type, instruction name, and data processing method respectively. The data type is usually located in front of instruction name, and the data processing method is located after the instruction name (Limited to a few of them).

5.3.3.1 Structure by data type

(1) By data size

- 1) Bit data type instruction
It has an instruction structure of Bxxxx after Bit's B.
Ex) **BMOV**, **BMOVL**, **BMOVG** etc.
- 2) Nibble data type instruction (4bit)
It has an instruction structure of Nxxxx after Nibble's N.
- 3) Half word data type instruction (8bit)
It has an instruction structure of Hxxxx after Half Word's H.
- 4) Word data type instruction (1word)
It has an instruction structure of xxxx without Word name.
Ex) **MOV**, **MOVL**, **MOVG** etc.
- 5) Double word data instruction (2word)
It has an instruction structure of Dxxx after Double word's D.
Ex) **DMOV**, **DMOVL**, **DMOVB** etc.
- 6) User-defined data type instruction
It has an instruction structure of Axxxx, after Any bit's A.
Ex) **AOR**, **AAND**, **AXOR**, etc.

(2) By data sign

There are signed and unsigned data types, and the former is typically used with omitting its name. On the other hand, the latter is used with "U" and "U" is positioned in the far last part of the instruction name.

If there is name according to data processing, in case of (xxxL, xxxG) it is placed to the back. For further details, refer to '0

Structure by data processing'

- If there is no data processing method part: **MULU**, **ADDU**, **SUBU**, etc.
- If there is a data processing method part: **MULLU**, **ADDLU**, **SUBLU** etc.

(3) By BCD data

BCD data has an instruction structure of xxxB after BCD's B.

Be sure that the data processing method part (List, Group) is always positioned after the BCD part.

- If there is no data processing method name. (1 : 1 process): **ADDB**, **MULB**, **SUBB**, etc.
- If the data processing method name is 'List': **ADDBL**, **MULBL**, **SUBBL**, etc.

5.3.3.2 Structure by data processing

(1) 1:1 processing instruction

It has an instruction structure of xxx with omitting the name.
Ex) MOV, ...

(2) 1:N processing instruction

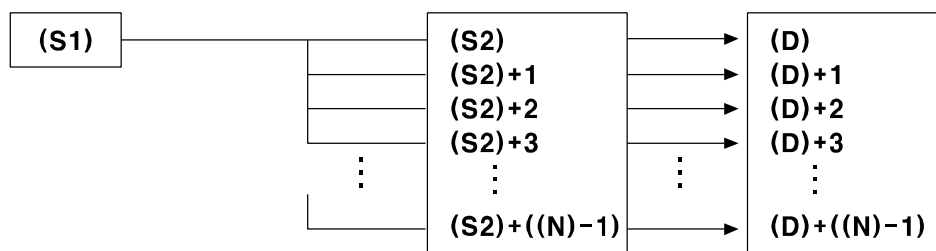
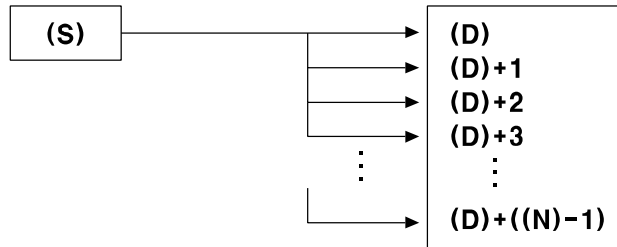

It has an instruction structure of xxxL after List's "L".
Ex) MOVL,

(3) N:N processing instruction

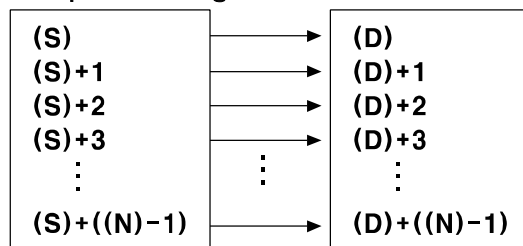

It has an instruction structure of xxxG after Group's "G".
Ex) MOVG, ...



Note

Operand

- S: Represents source device
- D: Represents destination device
- N: Represents the number of devices

Autonics

Sensors & Controllers

www.autonics.com

Distributor



Major products

Proximity sensors • Photoelectric sensors • Area sensors • Fiber optic sensors • Door/Door Side sensors • Pressure sensors • Rotary encoders • Sensor controllers • Switching power supply • Temp. controllers • Temperature/Humidity transducers • Power controllers • Recorders • Tachometer/Pulse(Rate) meters • Panel meters • Indicators • Signal converters • Counters • Timers • Display units • Graphic panel • Stepping Motors & Drivers & Motion controllers

Any proposal for a product improvement and development: Product@autonics.com

Headquarters

41-5, Yongdang-dong, Yangsan-si, Gyeongnam, 626-847, Korea

Overseas Business Dept.

Bldg. 402 3rd Fl, Bucheon Techno Park, 193, Yakdae-dong, Wonmi-gu, Bucheon-si, Gyeonggi-do, 420-734, Korea

Tel: 82-32-610-2730 / Fax: 82-32-329-0728 / E-mail: sales@autonics.com

Brazil

Autonics do Brasil Comercial Importadora Exportadora Ltda

Tel: 55-11-3055-1660 / Fax: 55-11-3055-1661 / E-mail: vendas@autonics.com.br

China

Autonics electronic(Jiaxing) Corporation

Tel: 86-573-8216-1900 / Fax: 86-573-8216-1917 / E-mail: china@autonics.com

India

Autonics Corporation - India Liaison Office

Tel: 91-22-2781-4305 / Fax: 91-22-2781-0538 / E-mail: india@autonics.com

Indonesia

PT. Autonics Indonesia

Tel: 62-21-6586-6740 / Fax: 62-21-6586-6741 / E-mail: autonics@cbn.net.id

Japan

Autonics Japan Corporation

Tel: 81-3-5730-0568 / Fax: 81-3-5730-0569 / E-mail: ja@autonicsjp.co.jp

Malaysia

Mal-Autonics Sensor Sdn. Bhd.

Tel: 60-3-7805-7190(Hunting) / Fax: 60-3-7805-7193 / E-mail: malaysia@autonics.com

Mexico

Autonics Mexico Sales Office

Tel: 52-55-5207-0019 / Fax: 52-55-5207-0099 / E-mail: ventas@autonics.com

Russia

Autonics Corp. Russia Representative Office

Tel/Fax: 7-495-745-2343 E-mail: russia@autonics.com

Turkey

Autonics Otomasyon Ticaret Ltd. Sti.

Tel: 90-212-222-0117 (PBX) / Fax: 90-212-222-0108 / E-mail: info@autonics.com.tr

USA

Autonics USA, Inc.

Tel: 1-847-680-8160 / Fax: 1-847-680-8155 / E-mail: sales@autonicsusa.net

Vietnam

Autonics Vietnam Representative Office

Tel: 84-8-3925-6563 / Fax: 84-8-3925-6564 / E-mail: vietnam@autonics.com